

CORE LESSONS

Citizenship

Keeping Current With Current Events..... 1

General Military Subjects

History of Drill.....	9
Introduction to Drill.....	13
Blue Dress Uniforms.....	23
The First Position – Standing.....	29
Aiming and Firing.....	37
Sight Adjustment and Scoring.....	43
The Prone Position.....	49
The Kneeling Position.....	57
Practice and Skill Development.....	63
Competition Opportunities.....	73

Keeping Current with Current Events

PURPOSE

This lesson will explain how to participate in discussions about current events. You will learn about different sources for current events information, and about the advantages and disadvantages of these different sources. You will learn about the role geography plays in the news, and how to relate events to their geographical locations.

All I know is what I read in the newspapers.

Will Rogers (Humorist)

Introduction

Research indicates that participating in current events discussions has many benefits. Knowing what is going on in your community, the nation, and the world makes you a more rounded person. By following current events, you will be able to speak intelligently to a variety of people, including:

- Teachers/Instructors
- Parents
- Friends
- Parents of friends
- Community members
- Employers

Definition of Current Events

“Current events” is simply defined as newsworthy occurrences that happen in the present time. Current events information is often referred to as “news.”

What Makes News?

Every day, editors around the world must make decisions about what stories they will publish or broadcast. Stories make it into the news for many reasons.

- **Timeliness.** News that is happening right now and is of interest to readers right now, a “hot off the press” item.
- **Relevance.** A story that happened locally or is of local interest, such as the appointment of a new school board member or football coach.
- **Magnitude.** The story is great in size or number. For example, a story about a tornado that took the roof off a house might not make the news, but if the tornado destroyed a community, it will probably be reported nationally.
- **Unexpectedness.** Something unusual or something that occurs suddenly and without warning.
- **Impact.** Something that will affect a large number of readers. For example, the terrorist attacks of September 11, 2001.
- **Reference to someone famous or important.** News about someone prominent or a famous personality. For example, the arrest of a famous basketball player.

- **Oddity.** A unique or unusual situation. For example, the birth of a baby panda bear at the National Zoo.
- **Conflict.** A major struggle. For example, a prison riot.
- **Reference to something negative.** Bad news often “sells” better than good news.
- **Continuity.** A follow-up or continuation to a story that has been in the news or is familiar.
- **Emotions.** Something related to emotions such as fear, jealousy, love, or hate increases the public interest.
- **Progress.** News of new hope, new achievement, new improvements.
- Reading about current events, whether on-line or off-line, will provide good models for writing. You will learn a lot about the **concise** writing of news writing.
- Seeking out sources for current events information will expose you to a variety of **media** and points of view.
- Keeping up on current events will reinforce and supply a context for your study of history.
- Knowing about and having opinions on current events will open a line of communication between you and your parents or other adults in your life.
- Current events discussions will provide new opportunities for conversations and debates with your classmates.

Why Study Current Events?

Why bother discussing current events? Developing good news knowledge skills and an awareness of current events will provide many advantages for you.

- Current events cover a wide range of subjects and intertwine with all areas of your school curriculum.
- Studying current events will expand your knowledge of the world, especially the geographical context.
- Studying current events will help build language, vocabulary, reading comprehension, critical thinking, problem solving, oral expression, and listening skills.
- Staying informed on current events will help you become an informed citizen and will help you develop good habits for life.
- Studying current events will expand your world beyond the confines of your school or your neighborhood.

Main Sources for Current Events Information

Current events information does not just come to you in one way. In today’s world, you have a lot of information available to you, from a variety of sources. Each source provides the information in its own way, and has its own set of advantages and disadvantages.

Newspapers

For a long time, newspapers were the main way that people in this country received information about current events.

Today, it is important to recognize that there are several different types of newspapers; each with its own criteria for determining what is “news.” For example, “gossip” papers may look for sensationalism. Local papers will have a different set of criteria than nationally recognized regional papers. Certain nationally recognized

papers are considered more reliable sources of information.

Advantages of Newspapers

- Reasonable purchase price
- Available in most locations
- Available in most languages
- Can be delivered to your door
- Reading newspapers improves scores on standardized tests, especially in reading, math, and social studies
- Reading newspapers improves vocabulary, word recognition, and comprehension
- Includes a variety of sections such as world news, national news, local news, sports, editorials, political cartoons, and weather
- Provides an opportunity for you to look for the “slant” of the reporter or the paper
- Depending on your outlook toward the source, you can learn what others view as important

Disadvantages of Newspapers

- Not up-to-the-minute due to printing and delivery time
- Can not be updated often during the day
- Some papers are politically slanted
- Sometimes hard to read due to comprehension level or requirement for prior knowledge
- Sometimes editorial policy is affected by the interests of advertisers
- Information is not indexed and may be difficult to find



Magazines

Many news magazines typically provide information about current events on a weekly or monthly basis. Some news magazines are theme-based, such as sports or politics, while some contain general information about recent news items.

Advantages of News Magazines

- Appeal to certain readers
- Quality of pictures may be better than newspapers
- News can be viewed with the benefit of elapsed time or larger political perspective
- May provide longer, in-depth articles

Disadvantages of News Magazines

- Not as frequent as newspaper or as timely as radio
- Can be costly
- Although there is typically a table of contents, information is not indexed and can not be cross-referenced

Television

Years ago very few people had televisions. Today, televisions are in most homes throughout the country. Some homes subscribe to cable or a satellite system. This gives people access to dozens, and sometimes hundreds, of stations. Many of those stations will be all news stations. Some networks carry news programming at certain prescribed times.

Advantages of Television

- Timeliness
- Availability of visual information
- Availability of issues-based debate
- Taps people's emotions more easily than some other media
- Makes you feel that you are right there where the news is happening
- News can be viewed at a regular time each day
- Programming can be interrupted to keep audience up-to-date
- Presentation skills may be observed and learned by viewers
- "All-news" stations provide continual coverage
- Talk shows provide analysis and perspective
- Can improve listening skills

Disadvantages of Television

- Too many commercials!
- Tapping people's emotions can be too easily used for propaganda
- Information can not be revisited to validate that you "got it right," unless you tape and replay
- No written language skills are gained

Internet

With the Internet, the entire world is at our fingertips. Headline news is available instantly and up-to-the-minute, as long as we have access. Thousands of Web sites are dedicated to an individual's or a group's view of the news.

Advantages of the Internet

- Timeliness
- Video and audio capabilities
- Vast amounts of information available
- Search engines help locate information
- Information can be indexed and cross-referenced
- Interactive involvement

Disadvantages of the Internet

- Need to ensure the source is reliable
- With so much information available, it is harder to weigh what "experts" think is important



Radio

Radio stations have been around for a long time. For many years, families in this country would gather around the radio to hear the latest about world and national news. This was especially true around the time of World War II.

Today there are many radio stations, in all parts of the country, dedicated to passing along the headlines and commentary. Even stations that play music, take time out to let you know what is going on in the world.

Advantages of Radio

- Can be heard in every car and home, in most locations
- Frequent updates
- Makes news available for visually impaired people
- Can give you the headlines in five minutes
- “All-news” stations provide continuous coverage

Disadvantages of Radio

- Cannot get reception in some areas
- Sometimes not as in-depth as newspapers or magazines
- Personalities with a specific slant can get a lot of air time (even daily or for hours at a time)
- Less diversity in opinion

Interviews

You have many well-informed people in your life. Whenever you have the opportunity, you should ask questions about activities that are going on around the world.

Advantages of Interviews

- Exposure to a variety of opinions
- Exposure to “opposite sides of the story”
- Draws upon the background knowledge of the person
- Draws from “everyday” people
- Develops questioning techniques

Disadvantages of Interviews

- People may not always be available
- While you need to filter out personal biases from all sources, interviews may expose you to a greater number of personal biases
- Information subject to misinterpretation
- You may not have sufficient background to pick up on the important or “true” material

The Five W’s and an “H”

The “who, what, when, where, why, and how” of a story can give you a very complete picture of what has occurred. Newspaper reporters often use the five W’s and an H as a guide to getting the whole story about which they are writing. Usually this information is found in the first paragraph of a news story. This paragraph is called the “lead.”

- Who? What are the names of the major “players” in the story? What role does each of them play in the events that took place or are taking place? How do they relate to each other?
- What? What are the facts about a particular event? What happened? What are the relevant details?

- When? What are the time-related issues about the event? When did it happen? How much time elapsed? When will the next occurrence take place?
- Where? What is the geography of this event? Where did it take place? What areas will be affected by the event?
- Why? What are the causes of this event? What factors led up to the event? What makes these types of events happen? What motivated the people involved?
- How? How did this event occur? What steps had to take place?

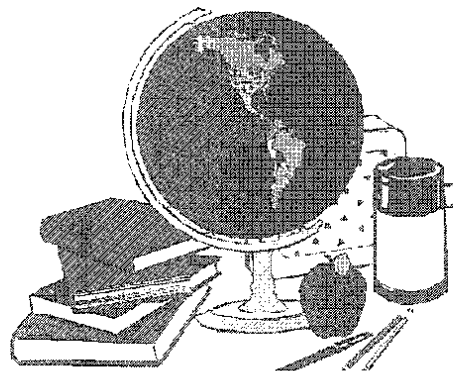

What Takes Place during a Current Events Discussion?

It is important to know how to participate in a current event discussion. Often, a discussion starts because someone has asked a question. Sometimes the best thing to do is clarify what the person has asked and be sure you have understood the question. Sometimes “answering a questions with a question” is a good move.

The next skill you can demonstrate is to listen to what others are saying before you enter the discussion. This will give you a context into which you can place your remarks.

During a current events discussion, you may hear people get emotional about a topic. We all have strong feelings about certain things.

Conclusion

Participating in current events discussions is a very important part of becoming an informed, well-rounded person. It is actually a right that you have as an American citizen, that citizens of some countries do not have. It is a right that you should take advantage of at every opportunity.

Seek out information about what is going on in the world. Collect that information from as many sources as you can. Look for the

The Geography Connection

In today’s world, it is critical that you have an understanding of current events in relation to where events take place in the world. Where countries are and how they relate to their neighbors and their environment is vital information for you to have while studying current events. Geography has influenced history and will always play an important role in future news.

It is a good idea to have a world or national map with you as you learn about or discuss current events. That way, you can look up the location of where the events took place and you can also learn about or discuss the impact of the geographical location. This will help you understand the news.

During a current events discussion, if you can relate the geographical location to the causes of an event, or the history leading up to the event, you will lend credence to your arguments and sound thoughtful and intelligent. For example, why do hurricanes tend to affect the Southeast coast of the U.S. more than the West coast?

U.S. MARINE CORPS. JROTC
Category 2 – Citizenship
Skill 2 – Civic Responsibility

geographical perspective. Develop a critical eye for examining current events and their place in history. Listen for viewpoints, and share your views with others. You will continue to learn and grow as an intelligent adult. You will earn the respect of others. ♦

U.S. MARINE CORPS. JROTC
Category 2 – Citizenship
Skill 2 – Civic Responsibility

The History of Drill

PURPOSE

This lesson introduces you to the history of drill. You will learn how the Romans brought drill into the battlefield, and how the Continental Army enlisted the help of Baron von Steuben to improve the battle readiness of the troops.

Introduction

Military history reveals that armies throughout the world have participated in some form of **drill**. The primary value of drill historically has been to prepare troops for battle. For the most part, the drill procedures practiced have been identical to the tactical **maneuvers** employed on the battlefield. Drill has enabled commanders to quickly move their forces from one point to another, mass their forces into a battle formation that afforded maximum firepower, and maneuver those forces as the situation developed.

Every group of people that has carved out an empire has used organized armies to secure the lands and people they wanted to control. Babylonians, Egyptians, Mongols, Chinese, and Romans all brought a new twist to warfare. Egypt gave us the chariot, Babylon the bronze sword, and Mongols, mounted cavalry, with the invention of the stirrup. The stirrup allowed the rider to stay in control of the horse, stay in the saddle, and have both hands free for sword and shield, or lance control during close combat.

The Romans brought to the playing field three upgrades: the **phalanx**, standardization of equipment, and drill. The phalanx was a body of heavily armed infantry formed in close deep ranks and files. The concept of drill is to train troops over and over until a task is second nature and everyone knows how the whole formation moves at any given time. Standardization allowed the Roman soldiers the ability to lock their shields together and form a moving wall of swords and spears. Drill allowed the soldiers to move in unison forming a moving battle formation. For its day, the Roman phalanx was a dominant force, and Rome went on to conquer a major portion of the world.



In 1775, when this country was striving for independence, the nation's leaders were confronted with the problem of not only establishing a government, but also organizing an army that was already engaged in active warfare. From the "shot heard around the world" on April 19, 1775, until Valley Forge in 1778, revolutionary forces were little more than a group of civilians fighting Indian-style, against well-trained, highly **disciplined** British forces.

For three years, General Washington's troops endured many hardships, including: lack of funds, rations, clothing, and equipment. Additionally, they suffered loss after loss to the superior British troops. These hardships and losses mostly stemmed from the lack of a military atmosphere in this country.

Recognizing the crisis, General Washington (through Benjamin Franklin, the American Ambassador to France) enlisted the aid of a Prussian officer, Baron Friedrich von Steuben. Upon his arrival at Valley Forge on February 23, 1778, **Baron von Steuben**, a former staff officer under Frederick the Great, met an army of several thousand half-starved, wretched men in rags. His first comment was, "No European army could be kept together in such a state." To correct these conditions, he set to work immediately, writing drill movements and regulations at night and teaching a model company of 120 men during the day.

Discipline became a part of military life for these selected individuals, and they learned to respond to commands without hesitation. This new discipline instilled in these soldiers a sense of alertness, urgency, and attention to detail. Confidence in themselves and in their weapons grew as each man perfected the movements. As they mastered the art of drill, they began to work as a team, and they developed a sense of pride in their unit.

Observers were amazed to see how quickly and efficiently von Steuben could form and maneuver the troops into different battle formations. Officers observed that organization, chain of command, and control were improved as each man had a specific place and task within the formation.

Later, General Washington dispersed the members of the model company throughout the

Army to teach drill. From this drill instruction, they improved the overall effectiveness and efficiency of the Army.

To ensure this uniformity and overall effectiveness continued, von Steuben wrote the first field manual for the U.S. Army in 1779: *The Regulations for the Order and Discipline of the Troops of the United States* (commonly referred to as the Blue Book). The Army did not change the drill procedures initiated at Valley Forge for 85 years, until the American Civil War. In fact, many of those original drill terms and procedures still remain in effect today.

Drill commands are about the same today as they were at the time of the War of 1812, except that then the officers and noncommissioned officers began them by saying, "Take care to face to the right, right, face." Also, during the American revolutionary period, troops marched at a cadence of 76 steps a minute instead of the current cadence of 120 steps. Then, units performed precise movement on the battlefield, and the army that could perform them best was often able to get behind the enemy, or on his flank, and thus beat him. Speed spoiled the winning precision. Also, firearms did not shoot far or accurately in 1776, so troop formations could take more time to approach the enemy.

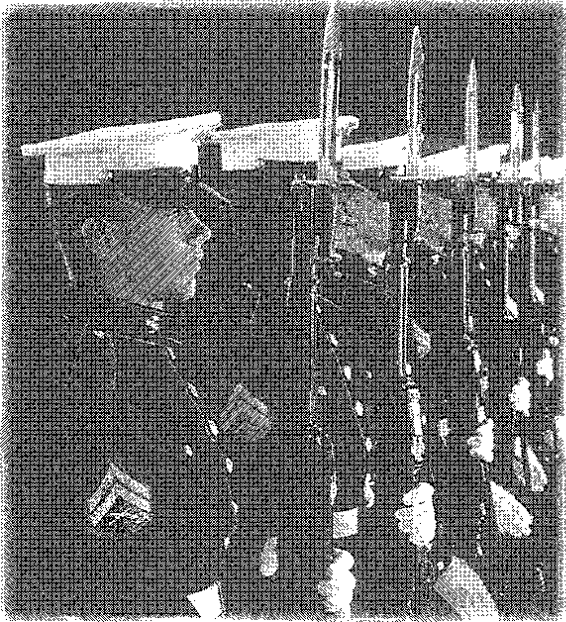

As armament and weaponry have improved, drill has had to adapt to new tactical concepts. Although the procedures taught in drill today are not normally employed on the battlefield, the objectives accomplished by drill are just as important to the modern Army as they were to the Continental Army.

Throughout history, armies have practiced drill. In times of war, leaders used drill to move troops and equipment quickly from one location to another in an orderly manner. Drills also show how troops can move as one in a flawlessly timed effort. These **unison** movements are still important on the battlefield where mistakes can cost lives. In peacetime, drill provides a means of enhancing morale, developing a spirit of cohesion, and presenting traditional and well-executed ceremonies.

When individuals react to commands rather than thought, the result is more than just a good-looking ceremony or parade. It is discipline! Drill has been and will continue to be the

backbone of military discipline. In addition to discipline, military drill teaches and develops:

- Teamwork
- Confidence
- Pride
- Alertness
- Attention to detail
- Esprit de corps

Conclusion

Through hard work and discipline, you can learn and develop the leadership skills and abilities necessary to become an effective leader in drill as well as in many other situations. An individual with pride and discipline will respond on command to produce the finest drill maneuvers in all of MCJROTC.❖

U.S. MARINE CORPS. JROTC
Category 5 – General Military Subjects
Skill 2 – Drill and Ceremonies

Introduction to Drill

PURPOSE

This lesson reviews the purposes and objectives of close order drill, and introduces you to the roles of leaders and followers in drill. The lesson discusses the different types of commands and the importance of command voice, and it prepares you for the practical application of drill.

The individual positions, stationary movements, facing, and hand salute are the basic skills required in drill. You will learn these positions and movements, and the correct execution of them.

"A true soldier embraces discipline. It is forged by the intensity of the drill."

- Move units from one place to another in a standard and orderly manner, while maintaining the best possible appearance
- Provide the troops an opportunity to handle individual weapons
- Instill discipline through precision and automatic response to orders
- Increase a leader's confidence through the exercise of command by giving proper commands and drilling troops

When individuals react to commands rather than thought, the result is more than just a good-looking ceremony or parade. It is discipline! Drill has been and will continue to be the backbone of military discipline. In addition to discipline, military drill teaches and develops:

- Teamwork
- Confidence
- Pride
- Alertness
- Attention to detail
- Esprit de corps

Introduction

Before you can become a leader and begin giving commands, it is important that you understand the basics of commands.

In order for drill to be successful, both the leaders and the followers must strive for perfection within their roles.

Purposes and Objectives of Close Order Drill

The five purposes of close order drill are to:

- Provide simple formations from which various combat formations can readily be assumed

Leaders and Followers

The instruction and practical application of drill are designed to strengthen your character, knowledge, and skills as an MCJROTC cadet. Drill and the application of basic leadership techniques will help you to develop in these areas.

In order for drill to be successful, individuals must either be in the role of leader or follower. Each of these roles assigns prescribed responsibilities.

Responsibilities of a Follower

The role you play and your responsibilities as a follower in drill are of great importance to the unit. By your obedience to unit leaders, your appearance, and your willingness to contribute to the unit's mission, you are showing the team spirit of a follower, helping to make the unit what it is, and contributing to its success.

As a follower, you share the same responsibilities of your leaders to uphold the basic values of loyalty to your unit, personal responsibility, and selfless service. It is your duty to complete your job to the best of your ability and to put the needs and goals of the unit before your own.

Responsibilities of a Leader

In your role as a leader, your responsibilities include setting a good example, knowing your job, and being concerned about the welfare of your followers. Further, you must show your obedience to your leaders and, at the same time, demonstrate the initiative of a follower. Finally, you must show ability and willingness to contribute to the success of your unit's missions.

You must show your leaders and followers that you uphold the same basic values of unit loyalty, personal responsibility, and selfless service. If you rise to the challenge of these responsibilities, you can make your followers feel confident in you, in themselves, and in the unit.

Commands and the Command Voice

The responsibilities of a leader include the proper use of command voice. When leaders give commands properly and with a good command

voice, they are helping to ensure that subordinates carry out their orders immediately and correctly.

How often have you heard a command given that demands immediate action? Your mom or dad may have given you that command about something as simple as mowing the lawn or cleaning up your room. Their authority came through loud and clear; the voice said, "Do what I say, NOW!"

The same thing happens in *Leadership Lab* except the commands come from drill leaders. If you are a leader, learn to give commands so that your followers clearly understand you and respond with immediate action.

Commands

A drill command is an oral order of a commander or leader. The precision with which personnel execute a movement is affected by the manner in which the commander or leader gives the command. Most drills have two parts: the preparatory command and the command of execution. Neither part is a command by itself.

The preparatory command states the movement that the leader wants subordinates to perform and it mentally prepares them for its execution. The command of execution signals when subordinates are to execute the movement. For example, in the command "*forward, march*," "*forward*" is the preparatory command and "*march*" is the command of execution. (Note: The command "*ready, aim, fire*" is an example of a two-part command that contains two preparatory commands.)

Once leaders give a preparatory command, they may command "*as you were*" to revoke that command. However, once they give the command of execution, any revocation is improper, and personnel should execute the movement in the best possible manner.

Some commands require the use of a **supplementary command** to reinforce other commands and to ensure proper understanding and execution of a movement. Supplementary commands, given by subordinate leaders, may be a preparatory command, a part of a preparatory command, or a two-part command. These commands extend to the lowest subordinate leader who has control over another element of the command within the same formation. The leader giving the initial preparatory command must allow sufficient time for subordinate leaders to give the supplementary commands before giving the command of execution.

Use the following basic rules to help you when giving commands. *These rules and accompanying examples may seem very difficult now to understand, but they show the complexity of commands in drill.*

- Give all commands from the position of attention.
- While at the **halt**, face the unit when giving commands.
- For marching commands, move simultaneously with the unit to maintain correct position.
- When marching, give commands in the direction of the troops.
- Subordinate leaders normally give supplementary commands over their right shoulder. However, you will learn several exceptions to this rule in later drill instruction.
- If a company is in formation, platoon leaders give supplementary commands following all preparatory commands of the commander. For example, when the preparatory command is “*company*,” platoon leaders immediately come to attention and command “*platoon*.”

The company commander then commands “*attention*.”

- Squad leaders do not participate in these commands. In addition, if the company commander gives the preparatory command “*parade*,” platoon leaders repeat it, but the squad leaders do not. The company commander then gives the command of execution “*rest*.”
- To change the direction of a unit when marching, leaders give the preparatory command and the command of execution for each movement so they begin and end on the same foot in the direction of the turn. For example, give the preparatory command “*column right*” and the command of execution “*march*” as the right foot strikes the ground. The **interval** between the preparatory command and command of execution is normally one count or one step.
- When a command requires the execution of a movement different from the other elements within the same formation, or at a different time, subordinate leaders give their supplementary commands at the time set by the procedures covering the movement. For example, your platoon is in a **column** formation. After the platoon leader commands “*column of twos from the left*,” the first and second squad leaders command “*forward*” and the third and fourth squad leaders command “*stand fast*.” On the command of execution “*march*,” the first and second squads execute the movement. At the appropriate time, the third squad leader commands, “*column half left, march*” for both the third and the fourth squads.
- The only commands that use unit designations such as company or platoon are “*attention*” and “*halt*.”

- Combined commands, such as “*fall in,*” “*fall out,*” “*rest,*” and “*at ease*” combine preparatory and execution commands, and do not require a supplementary command. Leaders give these commands with **inflection** and at a uniformly high pitch and loudness comparable to that of a normal command of execution.

Command Voice

A properly given command should be understood by everyone in the unit. Correct commands have three important elements: **tone**, **cadence**, and **snap**, and they demand a willing, accurate, and immediate response by everyone in the unit.

The Proper Tone of Command Voice

- **Voice Control:** Loudness is the key factor in tone control. The command must be loud enough so that subordinates can hear it and there is no doubt as to the action that the leader requires. To do this, you must project your voice without raising your hand to your mouth.

In most cases, the leader stands at the front and center of the unit, then, speaks facing the unit so that his or her voice reaches everyone. The command voice should come from the diaphragm -- the large muscle that separates the chest cavity from the abdominal cavity. The throat, mouth, and nose act as amplifiers to give fullness and to project the voice.

It is necessary for the voice to have carrying power, but excessive exertion is unnecessary and harmful. A typical result of trying too hard is the almost unconscious tightening of the neck muscles to force sound out. This produces strain, hoarseness, sore throat, and worst of all, indistinct and jumbled sounds instead of clear commands. You can achieve good voice control through good posture, proper breathing, correct adjustment of throat and mouth muscles, and confidence. The best posture for giving commands is the position of attention.

- **Distinctiveness:** Distinctiveness depends on the correct use of the tongue, lips, and teeth to form the separate sounds of a word or group of sounds into syllables. Distinct commands are effective; indistinct commands cause confusion. Leaders can pronounce all commands correctly without loss of effect if they speak their words correctly. To develop the ability to give clear, distinct commands, practice them slowly and carefully, prolonging the syllables. Then gradually increase the rate of delivery to develop proper cadence, but still pronouncing each syllable distinctly.

Distinct commands inspire cadets; unclear commands confuse them.
--

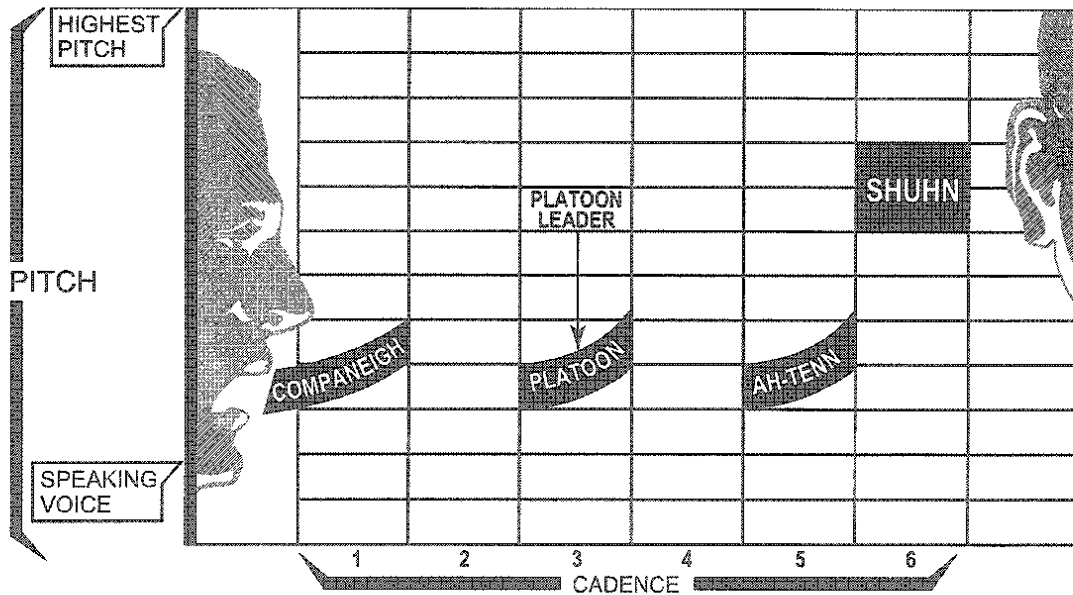

Diagram of a Command

- **Inflection:** Inflection is the rise and fall in pitch and the tone changes of the voice. Pronounce each preparatory command with a rising inflection. As shown in the diagram of a command, beginning a preparatory command is near the level of the natural speaking voice.

A common fault with beginners is to start the preparatory command in a pitch so high that, after employing a rising inflection, it is impossible to give the command of execution with clarity or without strain. When giving the command of execution, use a sharper tone and a slightly higher pitch than the last syllable of the preparatory command. Remember, the best way to develop a command voice is to practice.

In combined commands such as “*fall in*” or “*fall out,*” give them without inflection and

with the uniform high pitch and loudness of a normal command of execution.

The Proper Cadence of Command Voice

When giving commands, cadence is the uniform and rhythmic flow of words. Intervals between the words make the preparatory command understandable and signal when to expect the command of execution. These intervals also allow time for subordinate leaders to give any supplementary commands, as illustrated by the platoon leader in the preceding illustration.

When supplementary commands are necessary, the commander or leader should allow one count between the preparatory command and the supplementary command. The leader should also leave a count between the supplementary command and the command of execution.

The Snap of Command Voice and Movement

After the leader gives a command, there is a brief time between the end of the command of execution and the time when subordinates actually execute the move. The inflection of the command voice at the end of the command of execution should draw an immediate, sharp, and precise movement (or snap) to this command. If done properly, everyone in the unit moves at the same time -- creating an impressive, well-drilled, and uniform appearance. Remember, effective leaders depend on the command voice to show confidence in their ability to command.

Proper execution of commands and command voice takes practice. However, when leaders know their responsibilities and prepare for drill, they will discover that being a drill leader is a lot easier.

Stationary Movements

The individual positions and stationary movements are the basic skills required in drill. These basic skills are necessary to master because they are building blocks for other movements used during *Leadership Lab*. Additionally, they are important for you in developing discipline and self-confidence and for your unit in ensuring uniformity of movement and improving its overall effectiveness and efficiency.

Stationary movements include **attention** and **rest** positions, facing, and saluting. These movements, along with marching techniques, make up the squad and platoon movements. In drill, you start most of your movements from the position of attention; however, you will discover that in some instances, you execute certain rest movements from other rest positions.

Position of Attention

You assume the position of attention on the command “*fall in*” or “*squad (platoon, etc.), attention.*”

To assume the position of attention, bring your heels together sharply on line, with your toes pointing out equally, in a 45-degree angle. Rest the weight of your body evenly on the heels and balls of both your feet. Keep your legs straight without locking your knees. Hold your body straight with the level of your hips, chest lifted and arched, and shoulders square. Keep your head and face straight to the front, with your chin drawn in so that your head and neck are on a vertical line.

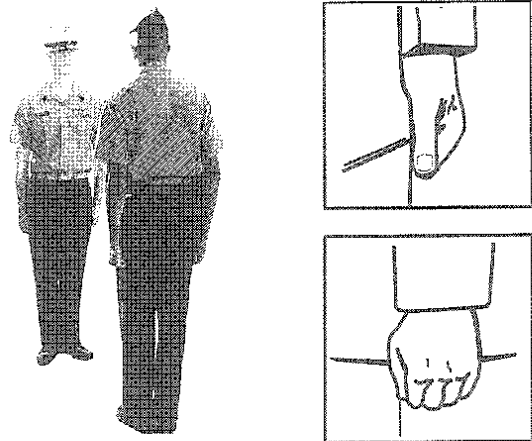

Let your arms hang straight without being stiff. Curl your fingers so that the tips of your thumbs are alongside and touching the first joint of your forefingers. Keep your thumbs straight along the seams of your trouser leg, with the first joint of your fingers touching your trousers. While you are in this position, stand still and remain silent unless otherwise directed.

Positions of Rest

Parade Rest

A drill leader can only give the command for this rest position from the position of attention. The command for it is “parade, rest.”

On the command of execution “rest,” move your left foot about 10 inches to the left of the right foot. Keep your legs straight without locking your knees, and rest the weight of your body equally on the heels and balls of both feet.

At the same time, center your hands at the small of your back on your belt. Keep the fingers of both hands extended and joined, interlocking your thumbs so that the palm of your right hand is outward. Keep your head erect as you would in the position of attention. Remember to remain silent and do not move unless otherwise directed.

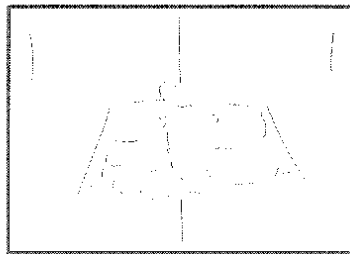

From the position of parade rest, you may execute “stand at ease,” “at ease,” and “rest.”

Stand at Ease

The command for this movement is “stand at ease.” On the command of execution “ease,” execute parade rest, but turn your head and eyes directly toward the leader of the formation. You may execute “at ease” or “rest” from this position.

At Ease

The command for this movement is “at ease.” On this command, you may move; however, you must remain standing and silent with your right foot in place. You may execute “rest” from this position.

Rest

The command for this movement is “rest.” On this command, you may move and talk unless otherwise directed. However, you must remain standing with your right foot in place. You may execute “at ease” from this position.

Facing

Facing, left or right, is a two-count movement. The command is “left (right), face.” On the command of execution “face,” slightly raise your right heel and left toe and turn 90 degrees to the left on your left heel, assisted by a slight pressure on the ball of the right foot. Keep your left leg straight without stiffness and allow your right leg to bend naturally. On the second count, place your right foot beside the left foot, resuming the position of “attention.” Your arms remain at your sides, as in the position of attention, throughout this movement.

The Hand Salute

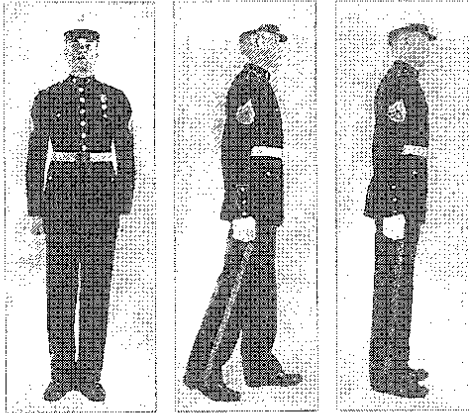

The hand salute is a one-count movement. The command is “*present, arms.*”

When a drill leader commands “*order, arms,*” you may release the salute. “*Order, arms*” is a one-count movement. On the command of execution “*arms,*” return your hand sharply to your side, resuming the position of attention. You execute the hand salute while marching alone; however, if you are a member of a unit, the leader salutes for the entire unit. If you are alone and at a **double time**, you must first come to **quick time** before you can execute the salute.

Facing to the rear is also a two-count movement. The command is “*about, face.*” On the command of execution “*face,*” move the toe of your right foot to a point touching the marching surface about half the length of your foot behind you. Rest most of your body weight on the heel of your left foot, and allow your right knee to bend naturally. On the second count, turn to the right 180 degrees on the left heel and ball of your right foot, resuming the position of attention. Again, your arms remain at your sides throughout this movement.

When reporting or showing courtesy to an individual, turn your head and eyes toward the person and salute at the same time. Subordinates initiate the salute at the appropriate time and terminate it upon **acknowledgment**.

Terminology

The chart that follows is a summary of relevant terms when studying close order drill.

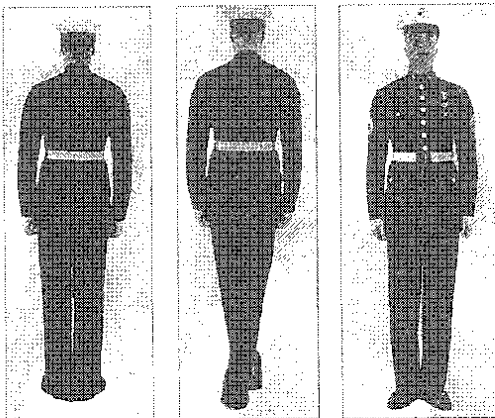

Term	Definition
File	2 or more cadets covered one behind the other
Rank	2 or more cadets aligned shoulder to shoulder
Line	Members or units aligned abreast
Column	Members or units organized into a file or files
Mass Formation	Platoons at close interval to form columns 6 or more files in a company or larger formation
Interval	One arm measured shoulder to shoulder
Close	4” measured shoulder to shoulder
Distance	40” measured back to chest between ranks
Open Ranks	70” measured back to chest between ranks

Cadence	Number of steps per minute
Quick Time	120-30 inch steps per minute
Double Time	180-36 inch steps per minute
Half Step	15-inch step measured from heel to toe
Back Step	15 inch step backwards
Side Step	12 inch step to the side measured between heels
Flank	90 degree pivot to the left while marching
Oblique	45 degree pivot to the left while marching
To the Rear	180 degree pivot to the rear while marching
Parade Rest	Relaxed position of attention and the hands are placed on the small of the back with the right hand on top of the left hand, fingers are straight with the thumbs interlocked
At Ease	Right foot remains in place, no talking allowed
Rest	Right foot remains in place, talking is allowed
Fall Out	Break ranks and go to the area designated by the leader

Conclusion

Use of command voice, and the proper execution of commands takes practice. However, when leaders know their responsibilities and prepare for drill, they will discover that being a drill leader is a lot easier.

In this lesson, you have learned the basics to completing stationary movements in drill. The stationary movements include the positions of Attention, Rest, Facing, and the hand salute. ♦

U.S. MARINE CORPS. JROTC
Category 5 – General Military Subjects
Skill 2 – Drill and Ceremonies

Drill Command Card

Movement	Left	Right	Left	Right	Left	Right
Column Left		Column	Left	****	March	
Column Right	Column	Right	****	March		
Column Half Left	Column	Half	Left	****	March	
Column Half Right		Column	Half	Right	****	March
By the Left Flank	By the	Left	Flank	****	March	
By the Right Flank		By the	Right	Flank	****	March
Left Oblique		Left	Oblique	****	March	
Right Oblique	Right	Oblique	****	March		
Forward from Left Oblique	For	Ward	****	March		
Forward from Right Oblique		For	Ward	****	March	
To the Rear	To the	Rear	****	March		
Change Step	Change	Step	****	March		
Halt from Left Oblique		Platoon	****	Halt		
Halt from Right Oblique	Platoon	****	Halt			
Close March in Column		Close	****	March		
Extend March in Column	Extend	****	March			
Eyes Right		Eyes	****	Right		
Ready Front	Ready	****	Front			
Mark Time from Quick Time	Mark	Time	****	March		
Forward from ½ Step or Mark Time		Forward	****	March		
Platoon Halt	Platoon	****	Halt			
Platoon Halt	Pla	Toon	****	Halt		
Right Shoulder Arms		Right	Shoui	Der	****	Arms
Left Shoulder Arms	Left	Shoui	Der	****	Arms	

Blue Dress Uniforms

PURPOSE

This lesson describes the Blue Dress uniforms. It provides information and descriptions on the four types of Blue Dress uniforms and the occasions for wear of these uniforms. Upon completion of this lesson, you will know how to properly wear the Blue Dress uniforms.

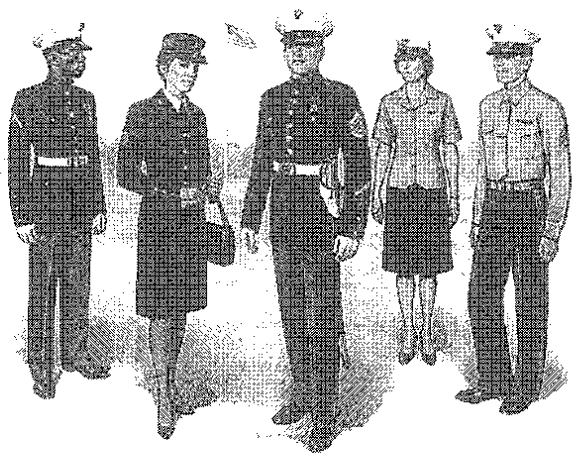

Introduction

You have previously learned about service uniforms that Marines wear for most day-to-day activities. In addition, there are uniforms designated for specific purposes or special occasions called Blue Dress uniforms. There are four kinds of Blue Dress uniforms. They are:

- Blue Dress “A”
- Blue Dress “B”
- Blue Dress “C”
- Blue Dress “D”

Blue Dress “A”

The Blue Dress “A” uniform is prescribed for parades, ceremonies, reviews, or official social occasions of formality, importance, or high honor. It will not be worn for leave or liberty. The uniform consists of a Blue Dress coat and trousers for males and blue coat and skirt or slacks for females. Large medals are worn and are the primary difference between the Blue Dress “A” and the Blue Dress “B” uniforms.



Blue Dress “B”

The Blue Dress “B” uniform is prescribed for parades, ceremonies, reviews, or informal social functions and uniform of the day. It may be worn for leave or liberty. The uniform consists of a Blue Dress coat and trousers for males and blue coat and skirt or slacks for females. Ribbons are worn on the Blue Dress uniform instead of the large medals worn on Blue Dress “A.”

Blue Dress “C”

The Blue Dress “C” uniform is prescribed for parades, ceremonies, and uniform of the day. It may be worn for leave or liberty. It consists of the long sleeve shirt and tie with blue

trousers for males and long sleeve shirt and necktab with blue skirt or slacks for females. The Blue Dress “C” uniform may also be worn with a blue sweater. It is prescribed as the uniform of the day.

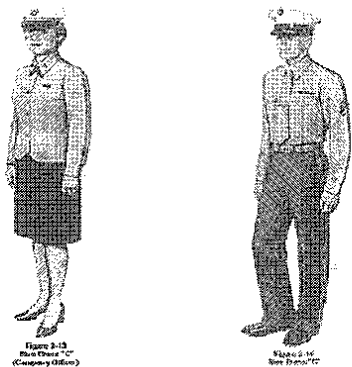

Conclusion

In this lesson, you learned about the four types of Blue Dress uniforms and the occasions for the wear of these uniforms. As a senior cadet, you may be afforded an opportunity to wear a Blue Dress uniform. Wear it proudly! ❖

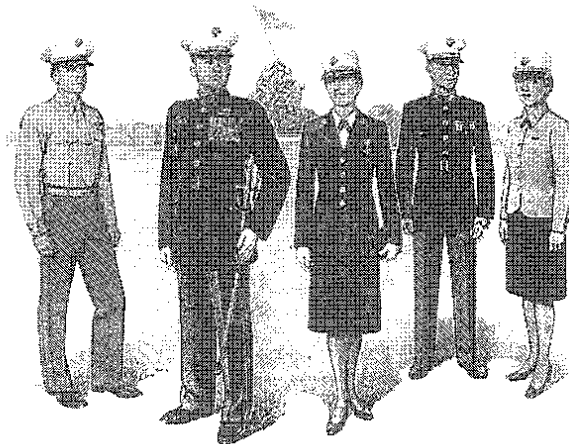

Blue Dress “D”

The Blue Dress “D” uniform is prescribed for parades, ceremonies, and uniform of the day. It consists of the short-sleeve shirt with blue trousers for males and short-sleeve shirt with blue skirt or slacks for female.

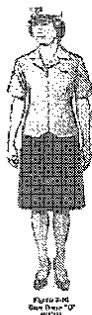

Dress Uniform Items

There are standard items prescribed by regulation that are worn with the Blue Dress uniform. A chart is provided to identify those items.

Uniform Explanation Chart

UNIFORM COMBINATION	DESCRIPTION	OCCASIONS FOR WEAR
Blue Dress "A"	Blue coat and trousers/skirt/slacks w/medals	Parades, ceremonies, formal, or semiformal social functions
Blue Dress "B"	Blue coat and trousers/skirt/slacks w/ribbons	Parades, ceremonies, informal social functions and uniform of the day.
Blue Dress "C"	Long-sleeve shirt and tie w/blue trousers/skirt/slacks	Parades, ceremonies, and uniform of the day
Blue Dress "C" with blue sweater	Long-sleeve shirt and tie w/blue trousers/skirt/slacks	Uniform of the day
Blue Dress "D"	Short-sleeve shirt w/blue trousers/skirt/slacks	Parades, ceremonies, and uniform of the day

Table 1: Uniform Chart

U. S. MARINE CORPS, MCIJROTC
 Category 5 – General Military Subjects
 Skill 3 – Uniforms, Clothing, and Equipment

Types and Components of Authorized Uniforms for Males

Designation	Cap	Coat/Belt or Jacket	Shirt	Necktie	Trousers/Belt	Gloves	Footwear	Outer coat		Insignia	Medals/ Ribbons	Badges	Sword
								(a)	(b)				
Blue Dress "A"	Dress	Blue w/strip collar	White plain front	None	Sky blue w/web belt or suspenders	White (b)	Black shoes and socks	All weather coat/optional boat cloak	Dress (collar/cap)	Large Medals	Not worn	Maybe prescribed	
Blue Dress "B"	Dress	Blue w/strip collar	White plain front	None	Sky blue w/web belt or suspenders	White (b)	Black shoes and socks	All weather coat/optional boat cloak	Dress (collar/cap)	Ribbons	Optional may be prescribed	Maybe prescribed	
Blue Dress "C" (c)	Dress	None	Khaki long-sleeve	Khaki w/ clasp	Sky blue w/web belt	(b)	Black shoes and socks	All weather coat (d)	Dress (cap)	Ribbons optional/maybe prescribed	Optional may be prescribed	Not worn	
Blue Dress "D"	Dress	None	Khaki short-sleeve	None	Sky blue w/web belt	(b)	Black shoes and socks	All weather coat (d)	Dress (cap)	Ribbons optional/maybe prescribed	Optional may be prescribed	Maybe prescribed	

Notes:

- a. If required or prescribed.
- b. Black gloves always worn or carried with all-weather coat during winter uniform period.
- c. Can be varied to include blue sweater
- d. Tanker jacket optional.

U.S. MARINE CORPS. MCJROTC
 Category 5 – General Military Subjects
 Skill 3 – Uniforms, Clothing, and Equipment

Types and Components of Authorized Uniforms for Female

Designation	Cap	Jacket	Coat or	Shirt	Necktab	Skirt/Slacks	Handbag/Purse	Gloves	Footwear	Outer coat (a)	Insignia	Medals/Ribbons	Badges	Sword
Blue Dress "A"	Dress	Blue		White plain front	Red w/skirt or black w/slacks	Blue skirt/slacks	Black handbag /clutch purse optional	White (b)	Black pumps (c)	All weather coat/ optional cape	Dress (collar/ cap)	Large Medals	Not worn	Maybe prescribed
Blue Dress "B"	Dress	Blue		White plain front	Red w/skirt or black w/slacks	Blue skirt/slacks	Black handbag /clutch purse optional	White (b)	Black pumps (c)	All weather coat/ optional cape	Dress (collar/ cap)	Ribbons	Optional may be prescribed	Maybe prescribed
Blue Dress "C" (d)	Dress	None		Khaki long-sleeve	Black	Blue skirt/slacks	Black handbag optional	(b)	Black pumps (c)	All weather coat (e)	Dress (cap)	Ribbons optional/ maybe prescribed	Optional may be prescribed	Not worn
Blue Dress "D"	Dress	None		Khaki short-sleeve	None	Blue skirt/slacks	Black handbag optional	(b)	Black pumps (c)	All weather coat (e)	Dress (cap)	Ribbons optional/ maybe prescribed	Optional may be prescribed	Maybe prescribed

Notes:

- a. If required or prescribed.
- b. Black gloves always worn or carried with all-weather coat during winter uniform period.
- c. Oxfords may be worn. Oxfords always worn with slacks.
- d. Can be varied to include blue sweater.
- e. Tanker jacket optional

U.S. MARINE CORPS. MCJROTC
Category 5 – General Military Subjects
Skill 3 – Uniforms, Clothing and Equipment

The First Target Position - Standing

PURPOSE

This lesson introduces you to the first target position, which is the standing position.

Introduction

Target rifle shooting involves firing in three different shooting positions: standing, kneeling, and prone. These shooting positions originated with firing positions that once were taught to warriors and soldiers and were used in battle or hunting. Today, these traditional firing positions have evolved into specific shooting positions that are part of target shooting and are defined by competition rules recognized throughout the world.

Special Note.

The shooting position illustrations and descriptions in this Student Text are given for right-handed shooters. If you are a left-handed shooter, simply reverse the descriptions or visualize holding the rifle with the opposite hands that are shown.

The first shooting position taught in the JROTC rifle marksmanship course is the **standing position**. The photos here show both a champion shooter and a high school shooter firing in the standing position. The champion shooter was a competitor in the 2000 Olympic Games and won a bronze medal in the women's air rifle event. She is firing a precision air rifle and wearing

special clothing that is used in advanced target shooting. The other shooter is firing a sporter air and wearing the type of clothes that are used in school-age sporter class competitions.

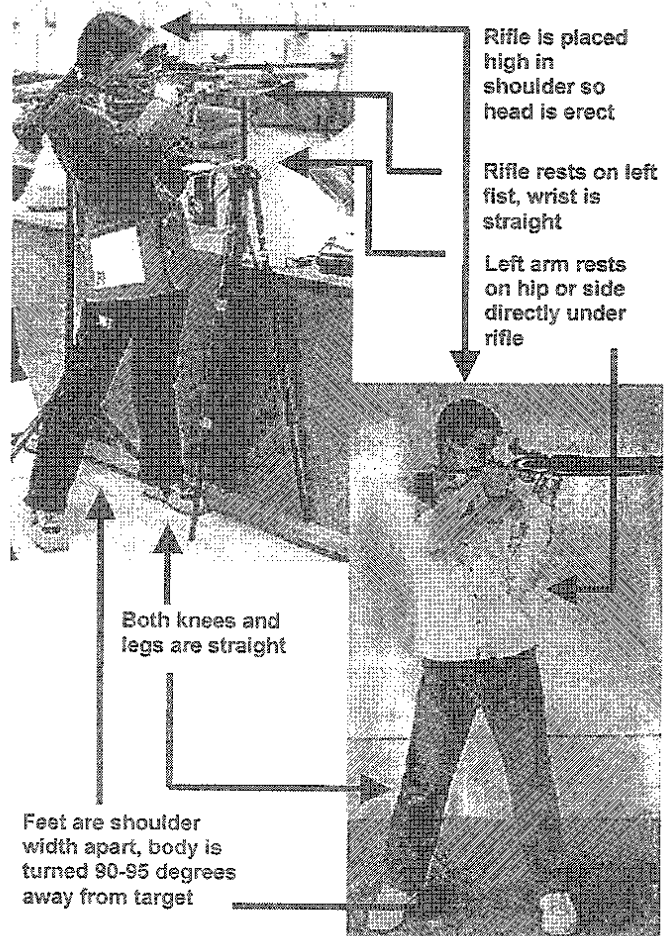

Notice how similar the two standing positions are. Visualize yourself in this same stance as you hold an air rifle while aiming at a target. Study the two photos carefully. The arrows point to specific things you should try to copy when you shoot in the standing position.

- The most important points about the standing position that you should try to reproduce in your standing position are: The feet and body are turned so that the body faces at least 90 degrees away from the target and the left side is pointed toward the target.
- The feet are shoulder width apart.
- Both legs and knees are straight. However, the muscles in the legs must be relaxed, not tense.
- The left arm must rest on the left side, directly under the rifle. The elbow can rest on the hip, or the arm can rest on the side, but it must always be directly under the rifle.
- The rifle rests on the left hand. Most shooters make a fist with their hand and rest the rifle on the fist. There are different support hand positions that are correct for different individuals.
- The rifle should be placed fairly high in the shoulder so that the head can be kept nearly erect. Choosing the correct support hand position makes this possible.

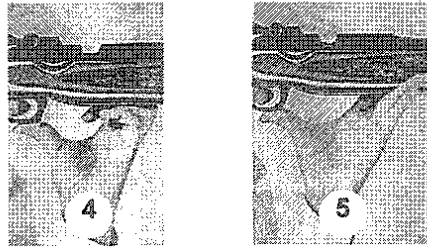
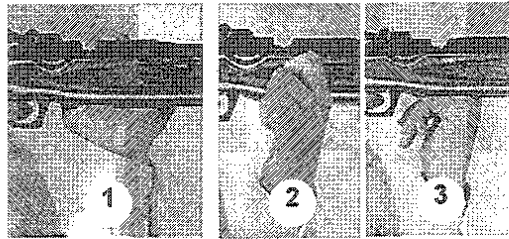

Illustrations 1-5 show different support hand positions for standing, from the lowest (open hand #1) to the highest on the (thumb and split fingers #5). Note that the wrist is bent only in the open hand position. The wrist must be held straight in all other hand positions.

The correct support hand position for you is the one that raises the rifle up to the level of your eye and the target. You should not simply copy the left hand position of another shooter. The relative lengths of your arms and torso determine the correct hand position variation for you. The illustrations here show different support hand variations for standing. These include the lowest hand position, for shooters with proportionately long arms or short torsos, as well as the highest hand position, which is best for shooters with long torsos and shorter arms. Select a support hand position for you, which will raise the rifle so that it is fairly high in the shoulder and your head is nearly erect.



One of the most critical points in building a correct standing position is to place the left (support) arm on the side of the body, directly under the rifle. When this arm is relaxed on the side of the body, the forearm serves as a steady brace to support the rifle. In shooting, bone support is much steadier than muscle support.

The standing position is the first shooting position that is taught because it is both the easiest shooting position to learn and the most challenging to master. The position is especially challenging because it has a smaller base of support and the body is higher. It is normally not as stable as the lower prone and kneeling positions where a sling can also be used to help stabilize the rifle. Slings may not be used in standing. Most shooters find that it takes more practice to develop the ability to hold the rifle still in standing.

Notwithstanding the challenges of developing a stable standing position, the position can produce amazing scores. The current women's world record for air rifle standing on the official competition target (the ten ring is a 0.5 mm dot that is about the size of the period at the end of this sentence) is a perfect 400 out of 400 possible

points. The men's world record is 600 out of 600 points.

Should I Shoot Right- Or Left- Handed?

Before you begin to shoot in any shooting position, you must decide whether you will shoot from your right or left shoulder and aim with your right or left eye. The best way to determine whether to shoot right-handed or left-handed is to determine which eye is your dominant or master eye. Someone whose right eye is dominant should shoot from the right shoulder. Someone whose left eye is dominant should shoot from the left shoulder.

A simple dominant eye test should be performed to determine which eye is dominant. Cut a one-half inch hole in a 3"x5" card. Hold the card at arm's length. With both eyes open, align the hole with a distinct object. Then bring the card back to your eyes while continuing to look at the object. If you continue to look at the object with both eyes open, the hole in the card will end up in front of the dominant eye.



Dominant eye test--Step 1

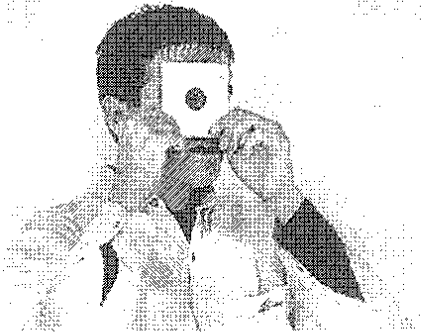

Dominant eye test--Step 2

There are also many people who are cross dominant. That is, they are right-handed and left-eye dominant or vice versa. There is some research that indicates cross dominant individuals may advance further in target shooting if they shoot from the same shoulder as their dominant eye, but the research is not conclusive.

For cross dominant persons who simply are not comfortable shooting from the same shoulder as their dominant eye, shooting from the other shoulder is acceptable. However, if this is done, it is very important to place a blinder on the rear sight to block the view of the dominant eye so that the eye that is used for aiming can concentrate on the rifle sights.

AIMING -- SIGHT ALIGNMENT

When learning to hold the rifle correctly in the standing position, the first practice exercises you will do involve aiming, holding, and dry firing at blank targets. To do that, you need to know how to align the sights and smoothly press the trigger.

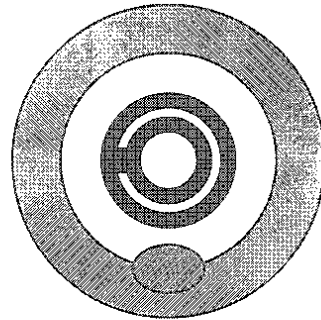

Sight alignment simply means to look through the rear sight iris to see the front sight and then to align it so that the front sight appears in the middle of the rear sight opening. When you place the rifle in your shoulder to hold it in the standing position, place your head on the cheek piece so that the eye you use to aim looks through the small hole in the rear sight. As you look through this hole, you should automatically see the front sight. To achieve proper sight alignment, simply move the front sight so that it appears in the center of the rear sight.

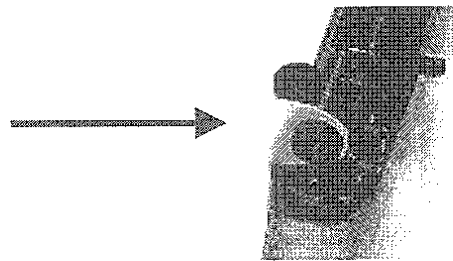

A rear sight blinder can be made from a piece of translucent plastic. Cut a hole in one end so that the blinder will fit over the detached rear sight iris.

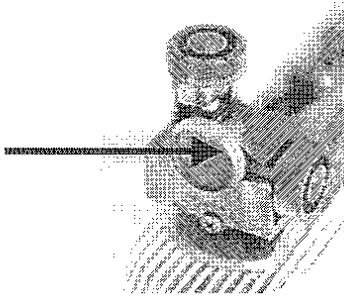

To align the sights, look through the small hole in the rear sight iris to see the front sight.

Pulling the Trigger

To dry fire while aiming at a blank target, it is necessary to first cock the trigger mechanism without charging the gas cylinder or loading a pellet in the breech. After the cocked rifle is placed in the shooting position, the shooter looks through the rear sight to properly align the front and rear sights, points the aligned sights at the center of the target and then completes the dry fire shot by smoothly pressing the trigger.

Some important points to master in correctly pulling the trigger are shown in the following illustrations.

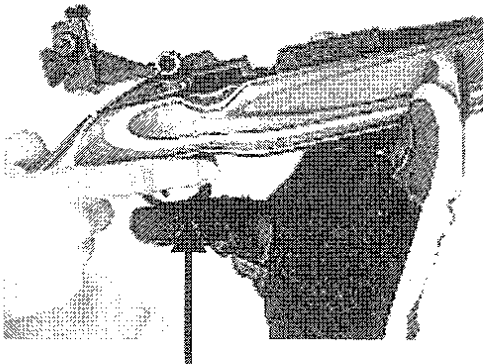

When you place the rifle in position, always keep the index finger outside of the trigger guard.

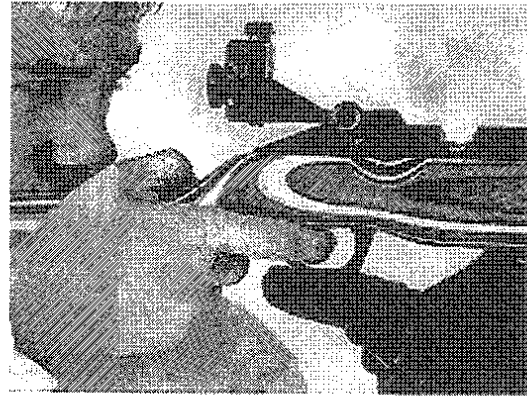

Align the sights on the target and then place the index finger on the trigger.

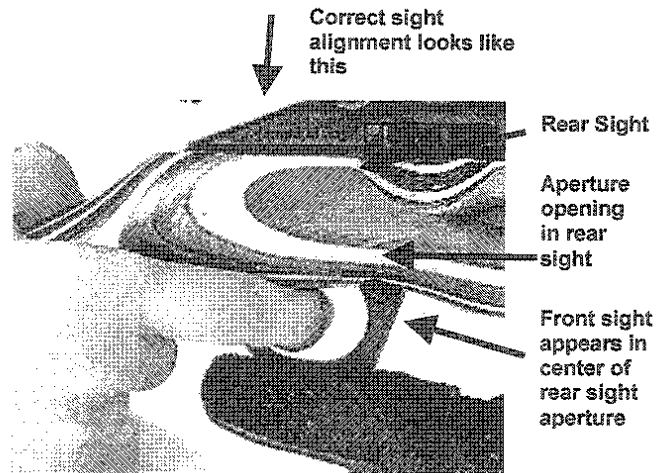

Take up the slack (first-stage) on the trigger and then, with the sights aligned on the target, smoothly press the trigger to the rear until the mechanism releases.

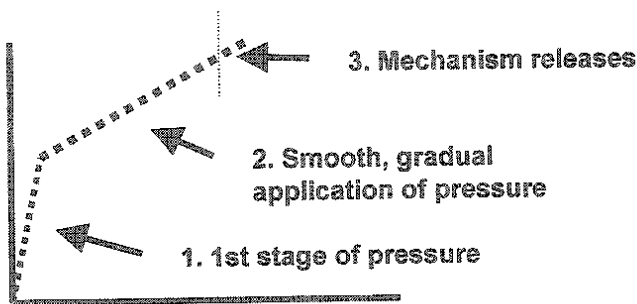

The graph shows how pressure is applied to the trigger. The time from the first application of pressure until the mechanism releases should be about 4-6 seconds.

Learning the Standing Position

Now, with a knowledge of what a proper standing position looks like, how to determine whether you should shoot right or left handed, how to select the proper support arm position, how to align the sights and how to release the trigger, you are ready to try the standing position yourself. Learning the standing position is easier if it is done in a sequence that follows these steps:

Study the position. Take one more look at the standing position photos. Study those model standing positions and visualize how you will place your body in the same position.

Get into position without the rifle. Take your position on the firing point and get into a standing position without the rifle. By doing this first without the rifle, it will make it easier to get your feet in the correct position and place your support arm on the side of the body correctly. Key position checkpoints are marked with arrows on the photo. Stand with your feet turned 90 degrees away from the target. Place your feet about shoulder width apart. Keep your body relaxed, but erect and look toward the target with your head. Fold the left arm and rest it on your

left side. Lift your right hand and imagine holding the rifle with it as the rifle rests on your left hand.

This is a good place to check the left hand position. The place where the rifle will rest should be at the same level as the chin (see dashed line on photo). If that support point is higher or lower, you should check lower or higher hand positions.

Get into position with the rifle. The next step is to pick up the rifle and get into the same position with the rifle. When you add the rifle to the position, begin by placing the rifle fairly high in the shoulder. The placement of the rifle butt plate in the shoulder is correct if the head is erect. If the head is bent down, the rifle is too low in the shoulder. Check the support arm position to be sure it rests on the side. A good way to check this is to be sure the arm is completely relaxed and that no muscles in the arm are used to hold up the rifle. Finally, check the left hand position. If the rifle is pointing below the target, try a higher hand position. If the rifle is pointing above the target, try a lower hand position.

Conclusion

This lesson details the correct way to achieve the standing position. Remember, all photos used in this lesson are for right-handed shooters, so if you are left-handed, reverse the descriptions. This lesson also explains if you are right-eye dominant for aiming, or left-eye dominant. ♦

Support point for rifle is at chin level

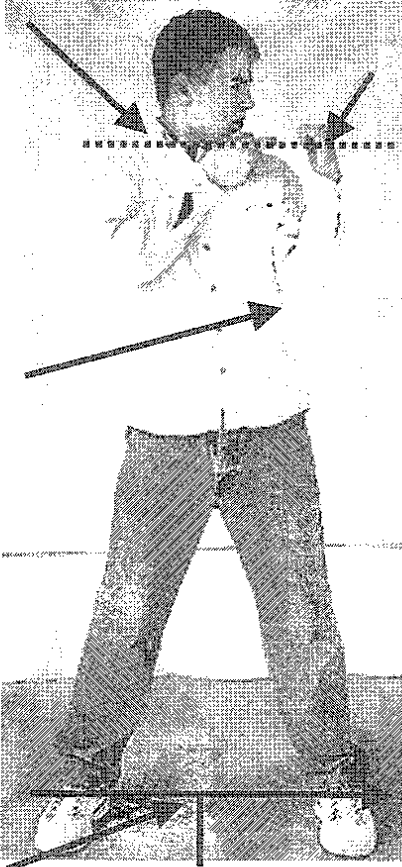

Arm rests on side

Butt plate is placed high to keep head erect

Left hand position raises rifle to level of target

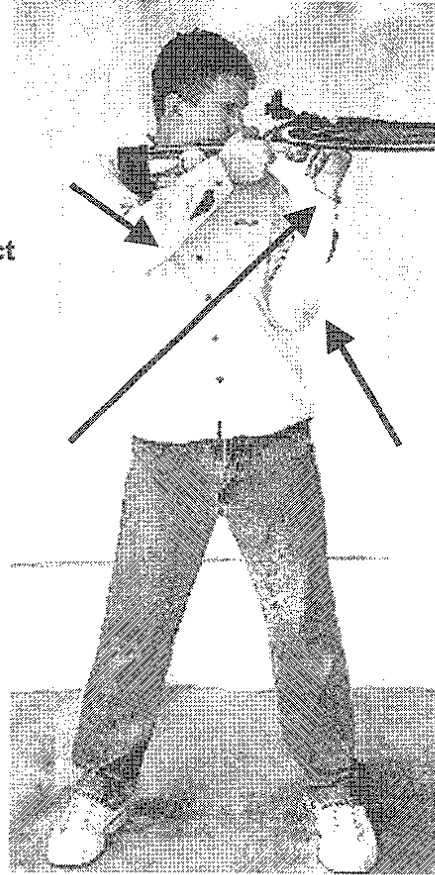

Arm rests on side directly under rifle

Feet turned 90 degrees, placed shoulder width apart.

U.S. MARINE CORPS. JROTC
Category 5 – General Military Subjects
Skill 8 - Marksmanship

Aiming and Firing

PURPOSE

This lesson introduces you to the basic techniques for firing an aimed shot at a target.

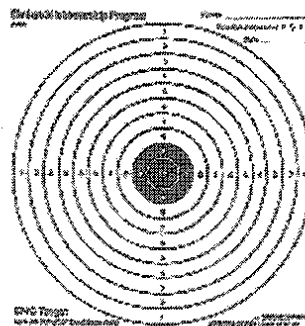

The BMC target is printed on a 6 1/2"x7" card, has a 15.25mm 10-ring and nine additional scoring rings that are each 15.25 mm larger.

Introduction

After you have learned how to assume the standing position and have dry fired several times at a blank target you are ready to prepare for live firing at actual targets. Aiming and firing actual shots at a target involves learning about some additional elements of target shooting that are covered in this chapter. These include targets, aiming and sight picture, proper breathing, and the coordinated technique of firing the shot. Developing a good shot technique is a critical factor for target shooters because it involves combining and coordinating the complex and simultaneous actions of aiming, breathing, holding, and trigger control.

The second target that will be introduced at the end of basic marksmanship instruction is the official competition target. The International Shooting Sports Federation and target shooting organizations all over the world accept the scoring ring dimensions on this target as official for their competitions. In the U. S., these targets are often printed so that ten competition or record targets and two practice targets appear on one target card. These targets are called "ten-bull targets."

Targets for Air Rifle Shooting

Two different targets are used in JROTC three-position air rifle shooting. The first target that is used is designed for marksmanship instruction. It is called the BMC (Basic Marksmanship Course) target. The BMC target has large scoring rings that are appropriate for new shooters who have not yet developed the ability to hold the rifle steady enough to fire all shots within the scoring rings of the official competition target.

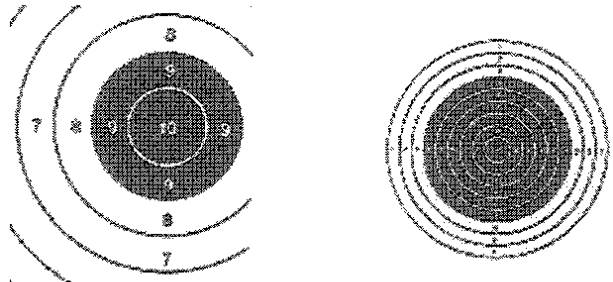
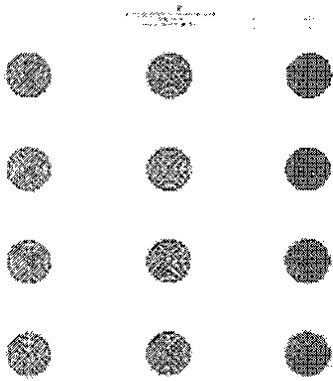

A comparison of the relative sizes of the scoring rings on the BMC and official air rifle targets. The size of the black area or aiming bull is the same on both targets.

The official 10-meter air rifle "ten-bull target" is printed on an 8 1/2" x 12" card. Each of its ten record and two practice targets have 0.5mm 10-rings (dots).

The much larger scoring rings on the BMC target are designed so that the shots fired by beginner shooters will still hit the target. After a few weeks of practice, all shooters will develop the ability to hold their rifles steadier and fire more accurately so that they can graduate to the official target. The official ten-bull target is the target that is most often used by JROTC and high school rifle teams for three-position air rifle competitions.

Breath Control

When you practiced holding an air rifle in the standing position on a blank target, you may have noticed that if you stop breathing while aiming you can hold the rifle steadier. To shoot rifles accurately, it is in fact, absolutely necessary to stop breathing while aiming and releasing the trigger. This is the only way to make it possible to hold the body still enough to consistently shoot tens on the official air rifle target.

Exhaling the breath is also a good way to help the body relax to calmly prepare to fire an accurate shot. To control the breath while firing a shot, simply breathe normally and then exhale naturally. Stop breathing after the breath is exhaled and hold the breath until the shot is fired. The breathing cycle for shooting should look like the illustration at the bottom of this page.

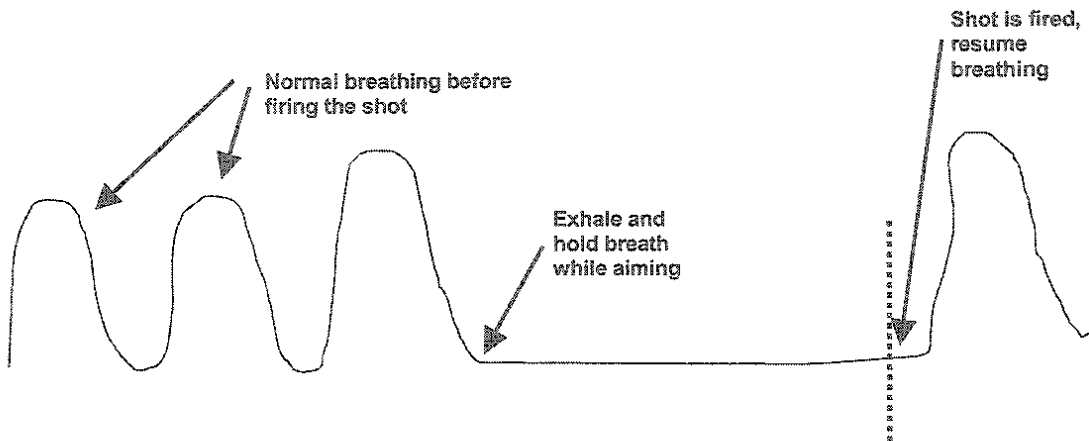

To develop the ability to shoot high scores on targets, it is necessary to learn how to aim with great precision. Your first practice in the standing position involved dry firing at blank targets where it is not possible to aim accurately because there was no bull's-eye to aim at. With a bull's-eye to aim at, it is possible to attain a complete sight picture and to aim very accurately by following two simple steps:

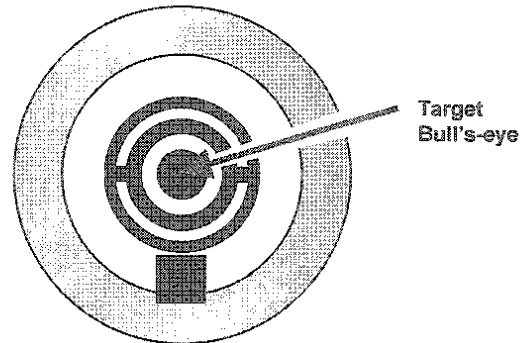

Aiming and Sight Picture

Step 1. Sight Alignment. You have already learned to align the sights by looking through the rear sight to see the front sight centered in the rear sight opening. The first step in attaining a complete sight picture is to align the sights.

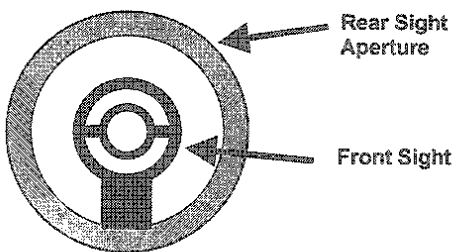

Step 2. Sight Picture. After aligning the sights, all that is needed to complete the sight picture is to point the aligned sights at the target so that the bull's-eye appears in the center of the front sight aperture.

Holding Steady

When you first held the rifle in the standing position it probably felt awkward and unnatural, but even after a few dry fire repetitions, the position began to feel better. When new shooters first try to aim at a target, it is normal for the front sight to move around over a large area. In the beginning, it is impossible to hold the front sight steady enough to keep the bull's-eye centered in the front sight ring. The only way to get the position to feel comfortable and natural and to develop the ability to hold the bull's-eye steady in the center of the front sight ring is to practice. Target shooting is a motor control skill where steadiness with the rifle can only be developed by practice.

It is natural to have some movement of the front sight aperture around the bull's-eye while aiming. The area or magnitude of this movement is called a shooter's "hold." As a beginner shooter, your hold may be quite large, covering much of the target. With practice, you will see that your hold gradually becomes much smaller and smaller. Champion shooters, in fact, develop hold movements that are no larger than three or four millimeters when measured on the 10-meter target.

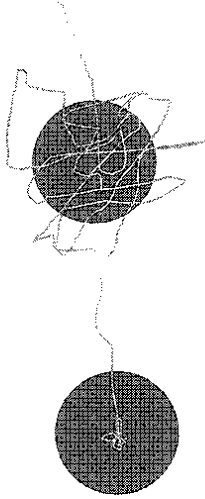

If a laser pointer were attached to the barrel, the "hold" movement trace of a beginner shooter might look like this.

Practice will make the hold movement trace of every shooter much smaller. Champion shooters are able to hold within the area of the ten ring on the official air rifle target.

The steadier you learn to hold your rifle, the higher your scores will be. Here are a few tips to practice that will help you hold your rifle as steady as possible.

Be sure your standing position is correct. Keeping the left arm on your side, directly under the rifle will do a lot to steady the rifle.

- Relax the muscles in your left arm and legs. Don't try to muscle the rifle to try to make it hold steadier.
- Accept your hold movement as natural. Just be sure to center the entire hold movement over the bull's-eye.
- The steadier you learn to hold your rifle, the higher your scores will be. Here are a few tips to practice that will help you hold your rifle as steady as possible.
- Be sure your standing position is correct. Keeping the left arm on your side, directly under the rifle will do a lot to steady the rifle.
- Relax the muscles in your left arm and legs. Don't try to muscle the rifle to try to make it hold steadier.

- Accept your hold movement as natural. Just be sure to center the entire hold movement over the bull's-eye.
- Concentrate on your sight picture. Think about letting the hold movements become smaller and keeping the bull's-eye movements inside the front sight ring.

Firing the Shot

Firing the shot involves putting all these separate elements or techniques together. This is called the shot technique. The shot technique includes:

- Loading the rifle.
- Lifting the rifle into position.
- Aiming by first seeing the front sight in the center of the rear sight (sight alignment) and then by bringing the front sight aperture onto the bull's-eye (sight picture).
- Taking one or two more breaths, exhaling and then holding the breath until the shot is fired.
- Centering the hold movements of the front sight over the bull's-eye.
- Smoothly pressing the trigger while the hold movements are centered.



Proper shot technique begins with loading and placing the rifle in position. Shot technique also includes aiming, breath control, hold control and trigger control.

Visualize how you will combine aiming, breathing, relaxing, keeping your rifle's hold movements centered over the target and smoothly pressing the trigger into a coordinated series of actions. In addition, remember again, developing the skills to hold a rifle steady and execute good shot technique comes from practice.

Shooting Groups on the Target

The range firing exercises that are done as part of this basic marksmanship lesson are very important because they are the first live firing that you will do at actual targets. Here are some things to remember as the instructor or range officer guides you through your first experience in shooting at bull's-eye targets from the standing position.

- **Range Commands/Instructions.** Be sure to follow the instructions of the instructor or range officer. Move to the firing line and pick up the rifle when told to do so. Do not load or begin to fire until the commands LOAD and START are given.
- **Standing Position.** Use the same standing position that was taught and practiced in the previous lesson.
- Turn your body 90 degrees away from the

target and stand with your feet shoulder width apart.

- Be sure your left arm rests on your side or hip so that it is directly under the rifle.
- Be sure you are using a support hand position that allows the rifle to be placed high enough in the shoulder that your head is erect.
- When you begin to aim, take one or two more breaths, exhale, and stop breathing.
- Relax your left arm and legs and let the rifle's hold movements settle down.
- Center the front sight movements over the bull's-eye and smoothly press the trigger.
- The instructor will probably first have you get into position and practice holding the rifle in the standing position while you concentrate on holding steady and keeping your hold movements centered.
- Next, the instructor will have you simulate firing the shot by making several dry fire repetitions.
- When you are instructed to load and fire the rifle, the instructor will have you shoot a series of shots (usually five shots).
- When you have finished firing, be sure to

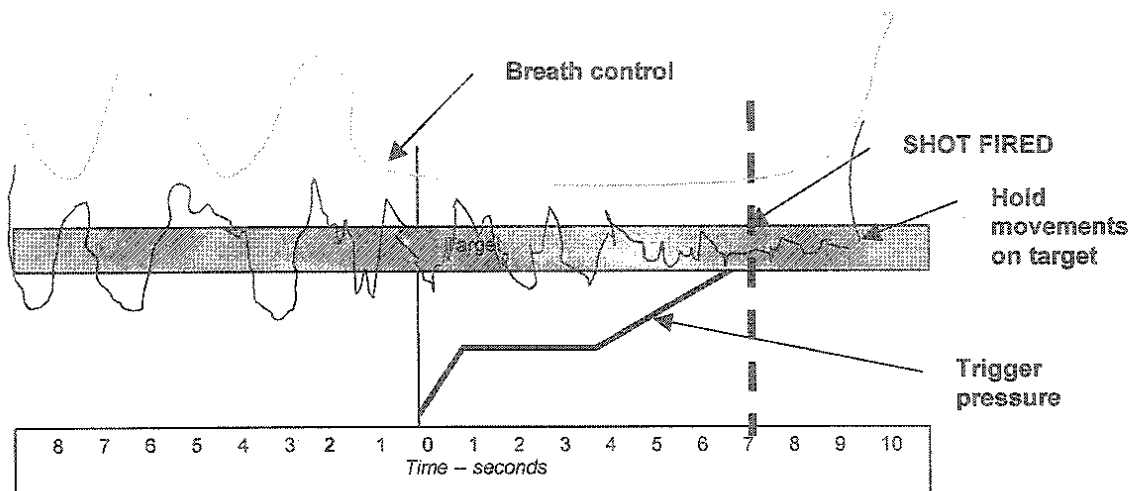

follow the instructor's commands to STOP, UNLOAD, and GROUND YOUR RIFLES. Open the bolt on your air rifle so the instructor can check to be sure your rifle is safe.

- The objective of this first firing exercise is to shoot a “group” of shots. At this point, it does not matter whether your shots are in the center of the target. The smaller your group of shots is the better you have done. You will be taught how to adjust the sights on your rifle so that your shot groups will hit the middle of the target in the next lesson.



When firing the shot, a key is to concentrate your attention on the sight picture to let it become steady. When the front sight is centered over the bull's-eye, smoothly press the trigger to fire the shot.

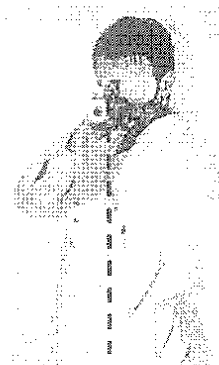

One of the keys to having a steady hold in standing is making sure the left arm is relaxed so that it rests on the side directly under the rifle.

Conclusion

This lesson taught you the basics of firing a shot. It described the two kinds of targets used for air rifle shooting, and how to take aim and fire. ♦

Sight Adjustment and Scoring

PURPOSE

This lesson introduces you to correct sight adjustment and scoring.

Introduction

During your previous range firing sessions you shot five-shot groups (series of five shots) in the standing position. This practice helps you become more comfortable with the position as well as to learn and coordinate the different actions involved in the technique of firing a shot. After you fire several five-shot groups, your groups become smaller. You will soon reach a point where you and the other cadets in your marksmanship class want to know what scores you can fire. Shooting for score is, after all, one of the most interesting challenges of target shooting. Scoring your targets allows you to determine whether your latest score beat your previous day's best or perhaps a personal record.

In target shooting, shots that hit the central scoring ring, the 10 ring, score the most points. Shots that hit each successive scoring ring outside of the 10 ring, score one point less until shots in the last scoring ring count one and then no points. To score the highest number of points on any series of shots, your shot groups must be centered on the target so that the 10 ring coincides with the middle of the shot group.

The correct way to move shot groups to the center of the target is to adjust the sights so that the next groups fired are centered. This is called zeroing the rifle. Some cadets may have

heard of "Kentucky windage" where a shooter aims away from the target center in an attempt to compensate for a rifle that is not zeroed. This means firing with an incorrect sight picture. That simply cannot be done consistently or with the kind of accuracy demanded in target shooting. If a shot group is not centered or zeroed, there is only one correct way to move the group to the center of the target. The sights must be adjusted.

In this lesson, you will learn how to adjust the sights on your rifle to zero your shot groups. You will also learn the correct method of scoring targets so that you can determine the scores that you are firing.

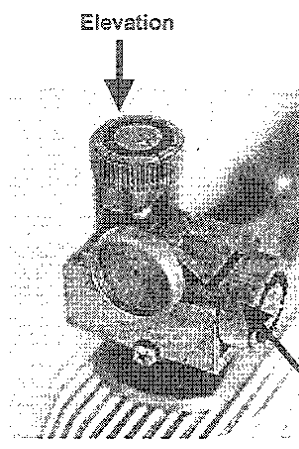
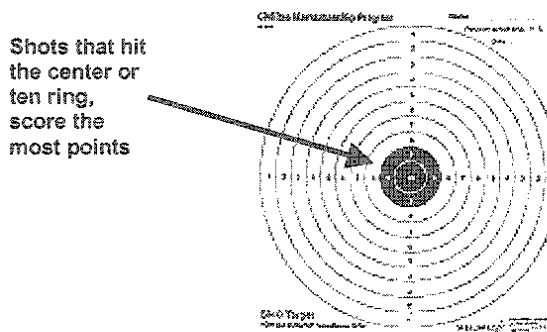

When the shot groups fire with a rifle are off-center, the only correct way to move them to the center of the target is to adjust the rear sight by using the elevation and windage adjustments on the sight.

Windage

How to Evaluate Shot Groups

In your first live firing in the standing position, it is not important that your 5-shot groups be in the center of the target. However, no matter where they are located on the target, it is important to **evaluate** your shot groups to know how you are progressing. Here are some things to look for in evaluating your shot groups.

- *Overall size of the group* - the smaller your shot groups are, the better you are doing.
- *Shot group location* - if your shot groups are always in the same location on the target, that indicates your position and shot technique are consistent.
- *Wild shots* - if your shot groups have wild shots or “fliers” that are away from the main group, those shots indicate a mistake in shot technique was made on that shot.

Excellent shot group, indicates good shooting performance

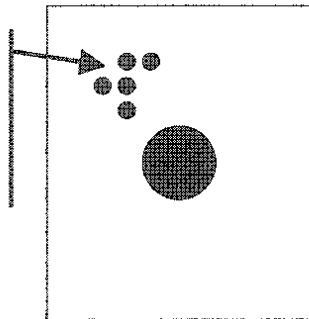

“Flier” away from main shot group indicates a mistake in shot technique

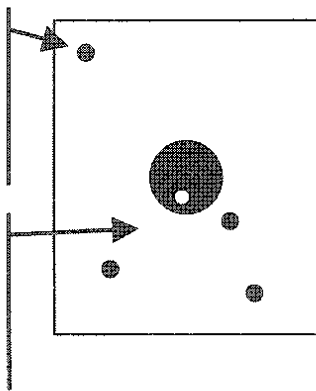

Large shot group indicates performance that improvement needs

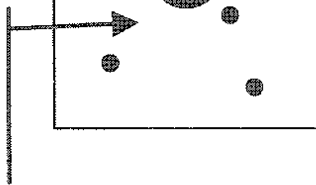

The next step in preparing to adjust your sights is to locate the center of your most recent shot group. Keep these points in mind as you determine shot group centers.

- Draw real or imaginary vertical and horizontal lines through the midpoints of the group.
- On shot groups with fliers, disregard any wild shots when determining the center of the group.
- Use the crossing point to mark the center point of the shot group.

Draw vertical and horizontal lines through center of group

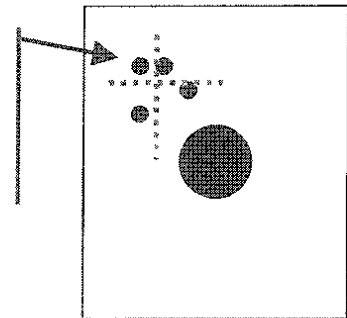

Disregard fliers when determining center of group

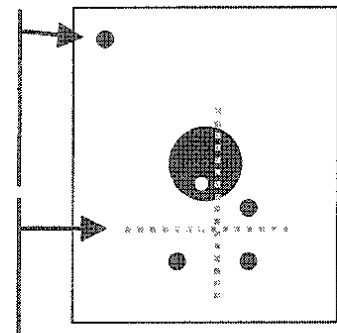

Draw lines through center of main part of group

Rear Sight Adjustment

As soon as you determine the center point of your group or the center point of the good shots in your group, you are ready to **calculate** the sight adjustments that are required

to place your next shot group in the center of the target.

To calculate and make the necessary sight adjustments, you need to be familiar with your rear sight and how it works. The most common rear sight is the Daisy sight that is on most Daisy M853 and M888 air rifles. The El Gamo sight is used on Daisy M753 and Crosman M2000 air rifles. Precision air rifles have similar rear sights except that these sights have more precise (finer) adjustments and their adjustment knobs move shot groups in the opposite directions from the adjustment knobs on sporter air rifle sights. Note these things when examining the rear sight on the air rifle that you use.

- Target sights have adjustment knobs that turn in increments called “clicks” that can be felt and counted.
- The sight adjustment knob on top of the sight is called the “elevation” knob. Turning that knob moves the shot group up or down. Look for the direction arrow on the knob to see which direction to turn the knob. For example, turning the elevation knob in the same direction as the “UP” arrow (clockwise) on the Daisy M853 sight moves the shot group up.
- The sight adjustment knob on the side of the sight moves the shot group left or right when it is turned. It is called the “windage” knob. Look for the direction arrow on the knob to see which direction to turn the knob. Turning the windage knob in the direction of the “R” arrow (clockwise) on the Daisy M853 sight moves the shot group to the right.
- Each click of change on a sight moves the shot group center a uniform distance. Check the sight adjustment chart to determine how many clicks of elevation and windage it will

take to move your shot group to the center. To move a shot group a distance equal to the distance between two scoring rings on the BMC Target, requires an adjustment of approximately 12 clicks.

Elevation knob,
turning knob
clockwise moves
shot group up

Windage knob,
turning knob
clockwise moves
shot group to
right

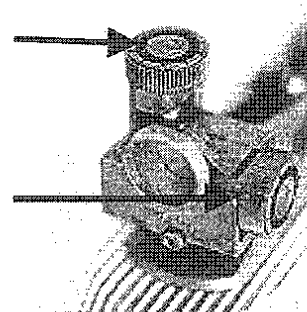

The Daisy rear sight is commonly used on Daisy M853 and M888 air rifles.

Elevation knob,
turning knob
clockwise moves
shot group down

Windage knob,
turning knob
clockwise moves
shot group to left

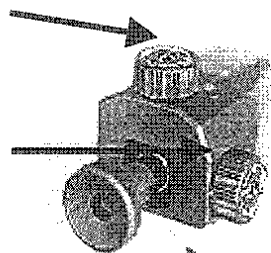

Precision air rifle sights have more precise adjustments. Their elevation and windage knobs often have directions marked in German and move shot groups the opposite direction from the Daisy and El Gamo sights.

Calculating Sight Adjustment and Establishing Zeroes

To calculate the sight adjustment needed to move your shot group to the center of the target, take the latest target you have fired and locate the center of the shot group. Then calculate and make the necessary sight adjustments

to correct your shot group by following these steps:

- Count the number of whole scoring rings from the horizontal line through the center of the group to the center of the target. In the illustration, this vertical distance is five scoring rings.
- Multiply the number of scoring rings in vertical distance times the number of clicks per ring for the target and sight you are using (use Sight Adjustment Chart). For a Daisy sight and the shot group in the illustration, the result would be 60 clicks (12x5).
- Turn the elevation knob on your sight, that number of clicks in the correct direction (down for group in illustration).
- Count the number of whole scoring rings from the vertical line through the center of the group to the center of the target. In the illustration, this horizontal distance is three scoring rings.
- Multiply the number of scoring rings in horizontal distance times the number of clicks per ring for the target and sight you are using (Use Sight Adjustment Chart). For a Daisy sight and the shot group in the illustration, the result would be 36 clicks (12x3).

- Turn the windage knob on your sight, that number of clicks in the correct direction (left for group in illustration).

After making the necessary sight adjustments, fire another group to see if the sight adjustment is correct. One or two additional, smaller sight adjustments may be required to place your shot group in the center of the target.

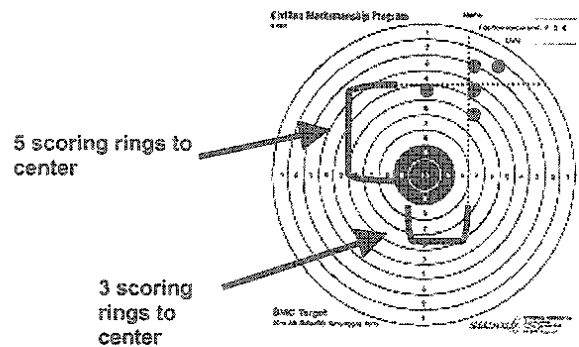

The Sight Zero

A sight is “zeroed” when it is adjusted so that the center of the shot group is the same as the center of the target.

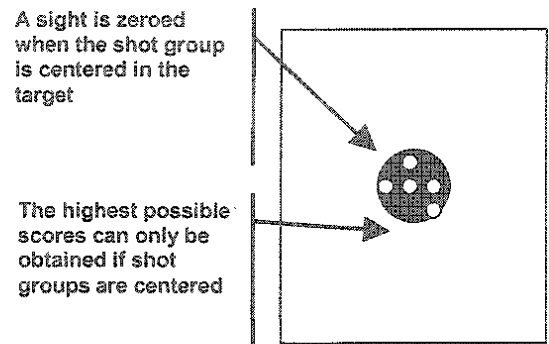

Air Rifle Sight Adjustment Chart				
Sight	To move zero up, turn	To move zero right, turn	Clicks per scoring ring, BMC Target	Clicks per scoring ring, official target
Daisy	Clockwise	Counter-clockwise	12	2
El Gamo	Clockwise	Counter-clockwise	24	4
PRECISION, Anschütz, FWB, etc.	Counter-clockwise	Clockwise	30	5-6
<i>The click adjustment values given here are approximate and may vary with different sights.</i>				

- When the shot group is centered on the target, the rifle is zeroed and the sight should not be changed unless subsequent groups are off center.
- Whenever a shot group is fired that is not centered, the necessary sight adjustments must be calculated and the adjustments made to the sight.
- Just because a sight is zeroed once does not mean it will stay zeroed. If a shooter's position or shot technique changes, the shot group center will change.
- Just because a sight is zeroed for one shooter does not mean it is zeroed for other shooters who use that same rifle. Unless two shooters use exactly the same position and technique, their zeroes will probably be different.
- One of the most important skills a target shooter must develop is the ability to continually evaluate whether his/her rifle sight is zeroed and to make changes when necessary to keep the sight zeroed.

How to Score Targets

After you learn to adjust the sights on your rifle so that your shot groups are centered on the target, you are ready to learn how to properly score targets. There are only a few rules that control the scoring of targets.

- The first rule is that a shot is scored according to the value of the scoring ring that it hits. If a shot is in the seven ring, it scores seven points (see illustration, shot #1).
- The second rule is that if a shot hole cuts two or three scoring rings, the shot is scored according to the value of the highest scoring ring it hits. If a shot cuts both the 9 and 10

rings, it scores 10 points (see illustration, shot #2).

- The third rule is that if a shot lies in one scoring ring, but just touches a higher value scoring ring, the shot is scored according to the highest scoring ring that any part of the shot hole touches. If a shot is in the eight ring, but just barely touches the nine ring, it scores nine points (see illustration, shot #3).

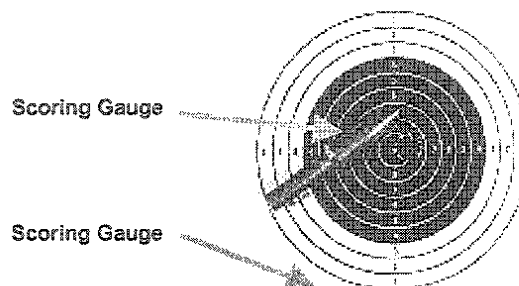
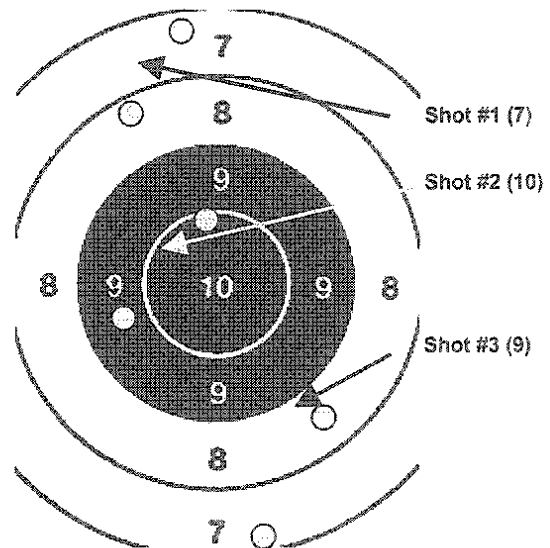

In official scoring, a scoring gauge is used to determine whether a doubtful shot touches a higher value scoring ring.

- The fourth rule is that if it is doubtful whether a shot hole touches a higher value scoring ring, a scoring gauge should be used. The scoring gauge, when used with a magnifying glass, allows the scorer to see exactly where the edge of the shot hole is, to determine the correct score for that shot. If a scoring gauge is not available, it is important to look carefully at the edge of the shot hole and to also use a magnifying glass to determine whether the edge of the hole touches a higher value scoring ring.
- The total score for a target is the total value of all shots on the target. At first you will fire five-shot groups where the maximum score is 50 points. Soon you will fire 10 shots on a target where the maximum score for the target will be 100 points.

Conclusion

In your next range firing exercises, you will have an opportunity to adjust your sights so that your shot groups hit the center of the target. With your shot groups centered, it is then possible to score your targets so that you can begin to make records of your progress as a shooter. ❖

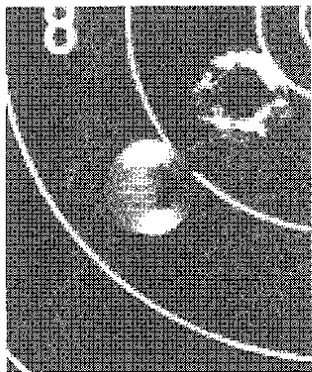

When a scoring gauge is inserted in a shot hole, it is possible to see exactly where the edge of the shot hole lies.

The Prone Position

PURPOSE

This lesson introduces you to the correct technique for firing in the prone position.

Introduction

The **prone** position has the lowest center of gravity and is the steadiest of the three target positions. Prone has extra stability because the shooter is allowed to use a **sling** in this position. A highly trained rifle shooter is capable of holding a rifle almost as steady in the prone position as a test cradle or machine rest can hold a rifle.

The 50-meter prone position world record is a perfect 600 out of 600 possible points. Firing at 50 meters is done with .22 caliber rimfire smallbore rifles on a target with a ten ring that is only 10.4 mm in diameter (A dime is 17.8 mm in diameter). Shooting a perfect world record score in the prone position means hitting a target that is over one-half of a football field away and less than 6/10ths the size of a dime 60 consecutive times. Even more astonishing is that six different shooters have fired perfect 600s eight different times in world record competitions.

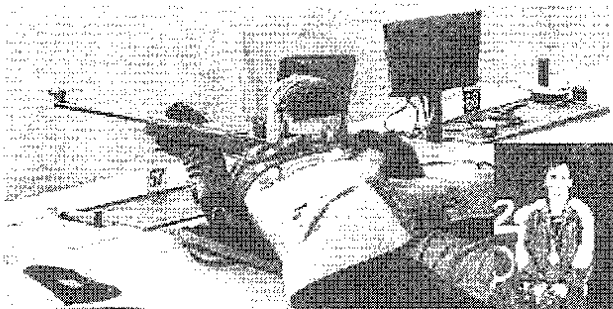

Sergey Martinov from Belarus is one of six shooters who have fired perfect 600x600 world record scores. Martinov has fired three 600s in world record competition

Features of Successful Prone Positions

The first step in learning any shooting position is to study the positions of successful shooters. The prone position photo below is the position used by world record holder Sergey Martinov. School-age shooters with sporter air rifles and clothing demonstrate their prone positions in the other photos.

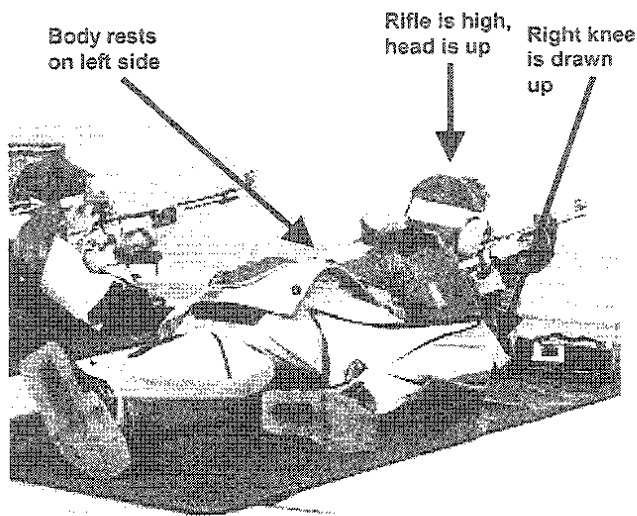

Proper Use of the Sling

Competition rules allow the use of a sling in prone and kneeling. Scores that can be fired with the sling are so much higher and more consistent than scores fired without a sling that all successful shooters use slings in those two positions (the use of a sling is not permitted in standing). It may be tempting to think that shooting in the prone position is easier without a sling, but trying to shoot without a sling would be a mistake. To learn the correct position and get the highest possible scores, a sling must be used in the prone position.

To take full advantage of the support that the sling provides, you need to understand how the sling is designed and used. The illustrations here show you how to place the sling on your arm so you will be ready to use it when you get into the prone position.

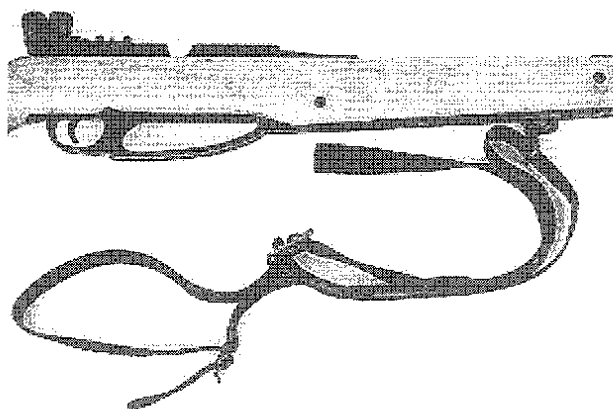
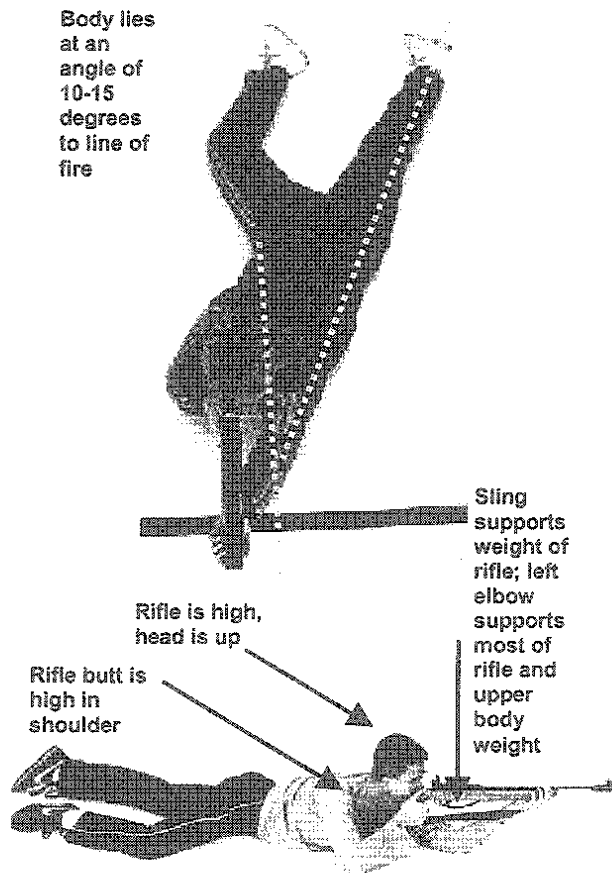

Again, check the similarities between the world record holder's position and the positions of the two school-age shooters. Carefully study the position features pointed out by the arrows and captions. Visualize how you will develop a prone position that is like these three excellent positions.

All target shooting slings have similar features. They include 1) an arm loop with a means of tightening the loop around the arm, 2) a buckle or other means of adjusting the sling length and 3) a sling attachment point that can be adjusted forward and backward.

Step 1.
Detach the
sling from
the rifle,
form a loop
for the arm



Step 2.
Place sling
loop high
on arm,
tighten
sling loop
around arm

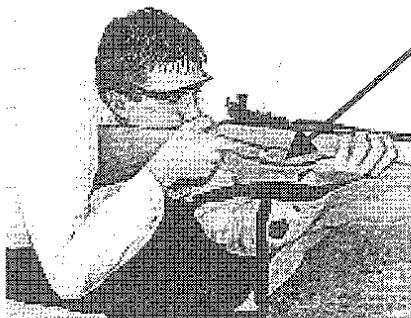
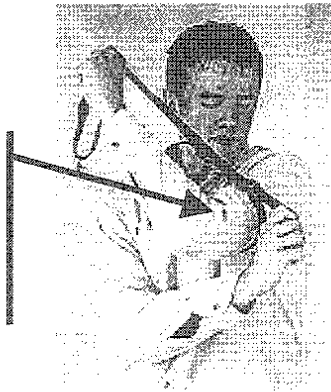

Sling
supports
100% of rifle
weight

The remaining steps to attach and adjust the sling are described in the prone position instructions that follow. With a properly adjusted sling, the muscles of the arm can be completely relaxed.

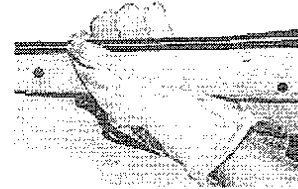

Wearing a glove on the support hand makes using the sling more comfortable. If a shooting glove is not available, a normal leather work glove may be worn.

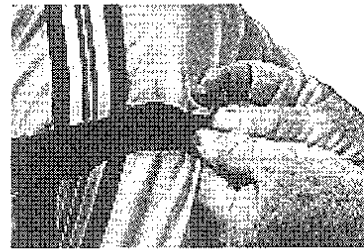

A large safety pin or other fastener may be used to keep the sling from slipping down on the arm.

Learning the Prone Position

A step-by-step process should always be used when learning a new shooting position. After studying the position and becoming aware of the importance of using the sling, it is time to move to the firing line and begin to develop your own prone position. Here are the steps to follow:

1. **Study the Position.** Take another look at ideal prone position photos. Imagine placing your arms, body and legs in a similar position. Put the sling on your support (left) arm so

that it will be ready when the time comes to attach it.

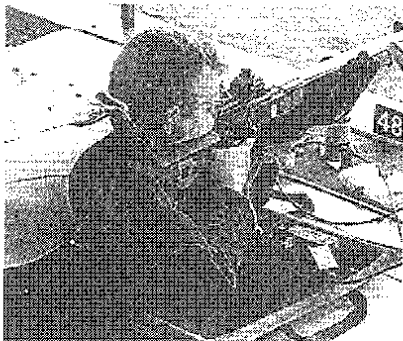

Major Mike Anti, U.S. Army Marksmanship Unit, is shown firing in the prone position during the 2000 Olympic Games. The photo on the left shows how the arms and sling support the rifle while keeping the butt high in the shoulder and the head up. The photo above demonstrates the angle that the body should lie in relation to the rifle. His right knee is drawn up to roll the body onto the left side. Note how erect his head is in both.

2. **Get into position without the rifle.** Start by placing your air rifle on the floor next to the shooting mat. Then place your shooting mat at an angle of about 10 degrees to the line of fire.

- Stand at the rear of your shooting mats. Kneel and lie down on the mat, facing the target. Your body should lie at the same 10 degree angle to the line of fire as the mat.
- Extend your left arm to the front and place your left elbow on the mat.
- Bring your right knee up and roll your body weight onto the left side.
- Place your right elbow on the mat to also help support the upper body. Position both hands as if they are holding an imaginary rifle.

With right knee drawn up, more body weight is on the left side and left elbow

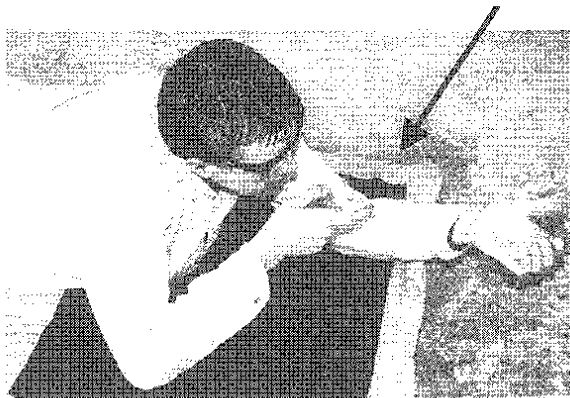

Get into the prone position without the rifle. Support the upper body with the left elbow and brace the body in position with the right elbow. Imagine holding a rifle in this position.

3. Get into position with the rifle, but without the sling. The next step is to pick up the rifle and hold it in position.

Place the butt plate high in your shoulder and close to the neck. The butt plate location is correct when your head is high enough that you can comfortably look straight forward to see your target.

Hold the rifle with both hands. Make sure your elbows are positioned so they comfortably support the upper body and rifle. Most of your weight should be on the support elbow.

While looking through the sights, move your support (left) hand forward and rearward on the fore end. This will determine where to locate the hand to raise the rifle to a point where the sights naturally point at the target.

When the correct support hand position is determined, mark that point on the fore end where the V between the thumb and hand rests. The instructor or another cadet can also assist you by marking that point.

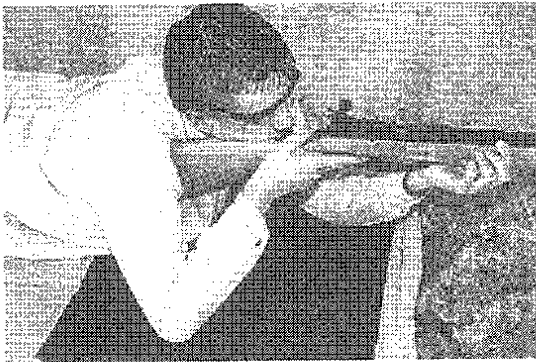

Add the rifle to the position. Move the left hand forward and rearward on the fore end until the front sight is at the level of the target. Mark the location where the V between the thumb and hand is located.

4. Attach and adjust sling.

- a. Attach the sling. Extend the sling and be sure it is adjusted so that its length reaches the extended finger tips of the left hand. Rotate the sling swivel one-half turn to the right (clockwise as you look at the sling swivel). Attach the sling to the sling attachment point (Daisy M853/753 rifles) or attach the sling swivel to the rail.

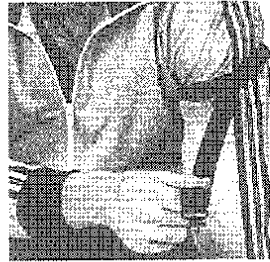

Extend the sling and rotate the sling swivel one-half turn to the right (clockwise direction).

- b. Get back into the same prone position you just had with the rifle and without the sling. This time the sling should be attached. The sling swivel should be forward of your hand and the sling should be loose. Wrap your arm around the sling so that the sling passes over the back of the hand and around the inside of the arm.



To properly place the arm in the sling, extend the arm and then rotate it clockwise around the sling so that the hand rests between the sling and fore end. The sling should pass around the back of the hand.

- c. Place your left hand in the same location that you marked previously. Check your position to be sure the rifle points comfortably at the center of your target. If the front sight rests above or below the target, move the left hand forward or rearward to get the sights on the target. Move the sling swivel to the location where the V between your thumb and hand is located and tighten it. The best way to do this is to have the assistance of an instructor or other cadet who can adjust the sling swivel by moving it back to the left hand position and tighten it in place.

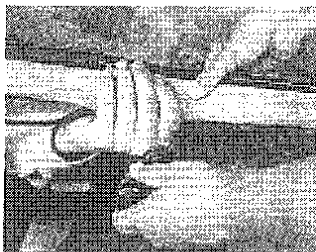

With the left hand in position, move the sling attachment or sling swivel back to the hand and tighten it in place.

- d. Complete the position by tightening the sling until it takes over the work of holding up the rifle. The sling should be tight enough so that no muscle effort by the arms is necessary to help hold up the rifle.

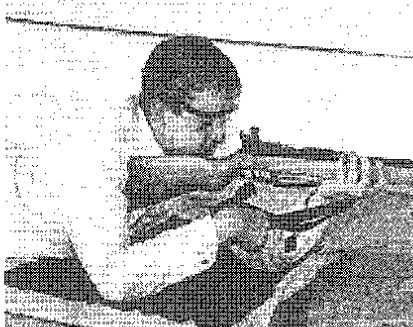

Finish the sling adjustment by tightening the sling until the sling and not the left arm muscles, do the work of holding up the rifle.

5. **Align the position.** After tightening the sling, one more step is necessary to be sure your prone position produces the smallest possible groups and highest scores. You must align your position with the target.

- Get into position and let the rifle point where it naturally wants to point, without trying to force the rifle to point at the target. A good way to do this is to close your eyes or look down while you relax your arms and upper body and let the sling support the rifle. Next, look through the sights to see where the rifle is pointing. If the sights are not aligned on the target, you need to align your position by moving your body.
- When aligning your body-sling-rifle system on the target, do not move the support (left) elbow. Use the support elbow as a fixed pivot point. If the rifle is too high or too low, use your feet to push the body forward slightly, to lower the rifle muzzle. Alternatively, use your feet to pull the body back slightly to raise the muzzle.
- If the rifle points to the left or right, use your feet to lift the body and gently shift it to the left or right to bring the rifle onto the target. Again, do not move the support elbow—always use it as the pivot point.
- Check position alignment again to be sure the sights now point naturally at the target. The prone and kneeling positions have a “natural point of aim” that must be aligned with the target.

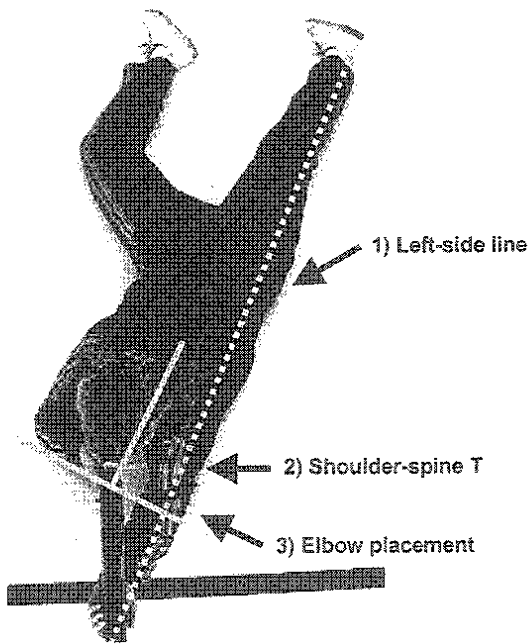
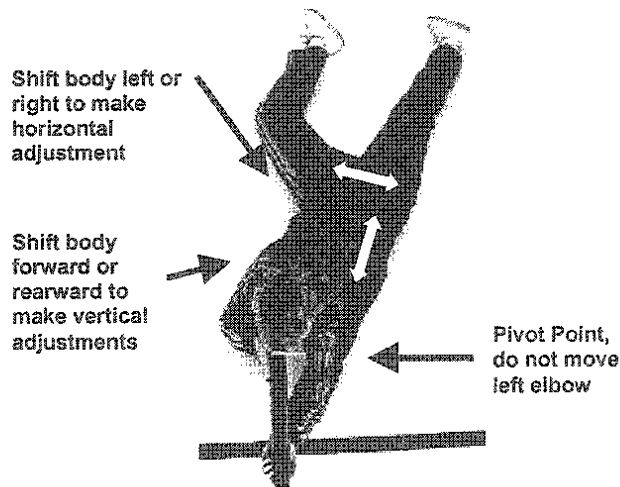

As you prepare to fire, here are three things to check to be sure that your position is correct. 1) Left-side line: You should be able to draw a straight line from the left hand through the left foot. 2) Left elbow placement: The elbow should be located directly under the left-side line. It should not be forced under the rifle. 3) Shoulder-Spine T: Lines drawn through the shoulders and spine should form a T.

Prone Position Firing

You should now be ready for dry and live firing in your new prone position. Your instructor will likely begin by doing several dry firing repetitions to practice aiming, breathing, centering your sight picture and smoothly pressing the trigger to release the shot without disturbing your aim.

To fire a series of shots in the prone position, it is also necessary to develop a successful technique for loading the air rifle in the prone position. Loading the air rifle in prone is more difficult than in standing. The method of loading that is used in the prone position depends on the type of air rifle that is used.

- Sporter air rifle, Daisy M853/753. With the pneumatic air rifle, it is necessary to take the rifle off the shoulder and then to take the hand out of the sling so that both hands are available to cock the rifle. The illustrations show two methods of cocking the pneumatic air rifle in the prone position
- Compressed air and CO2 rifles. Loading these rifles is simply a matter of dropping the rifle from the shoulder, opening the bolt, loading and pellet, closing the pellet and placing the rifle back in the shoulder for the next shot.

After your instructor gives the command START to begin firing in the prone position, think about relaxing your arms so that the sling does the work of holding the rifle. Center the bull's-eye in your front sight ring as perfectly as you can. You will still have some hold movement, so be sure to relax and center the movement within the front sight ring. When you have a good sight picture, smoothly squeeze the trigger until each shot fires.

When you finish firing, be sure to open the bolt on your rifle and wait for the instructor to inspect it.

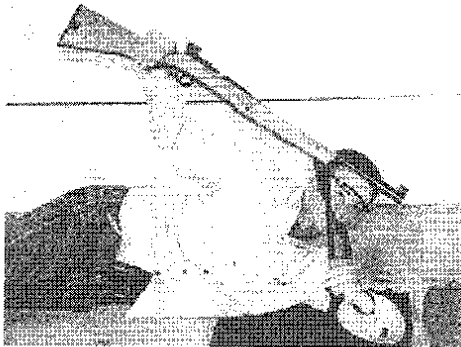

Method 1: Left elbow remains in place. Left hand comes out of sling and grasps cocking lever. Right hand pulls rifle to rear and then pushes it back forward to cock the rifle. The left hand is then repositioned in the sling and loading is completed by the right hand.



Method 2: Rifle is turned over and left hand holds rifle while right hand operates the cocking lever. The left hand is then repositioned in the sling and loading is completed by the right hand.

Conclusion

This lesson gives step-by-step directions for achieving the correct prone position. It also tells you how to use a sling. Firing accuracy in the prone and kneeling positions is greatly increased by using a sling. ❖

The Kneeling Position

PURPOSE

This lesson introduces you to the correct technique for firing from the kneeling position.

Introduction

In the kneeling position, the shooter kneels to sit on the right foot that is supported by a kneeling roll. The rifle is supported by the sling and left arm that rests on the left leg. The kneeling position is similar to prone in that the sling is also used in this position. It is similar to standing because the body's center of gravity is higher and precise balance is essential to achieving a stable kneeling position.

In the kneeling position, one additional item of equipment is used, a kneeling roll. It is possible to shoot kneeling by sitting on the side of the right foot, but only a few shooters have ever been able to use that position successfully. All of the top kneeling shooters in the world today use a kneeling roll. Its use is highly recommended.

If your unit does not have kneeling rolls available, it is easy to make suitable kneeling rolls. Pieces of heavy fabric can be sewn to form a cylinder that is eight inches long and six inches in diameter. Fill the cylinder about 80% full with birdseed, wood chips or other similar material. A kneeling roll can also be made by cutting a eight inch wide strip of carpet and rolling it into a kneeling roll, that is about four or five inches in diameter.

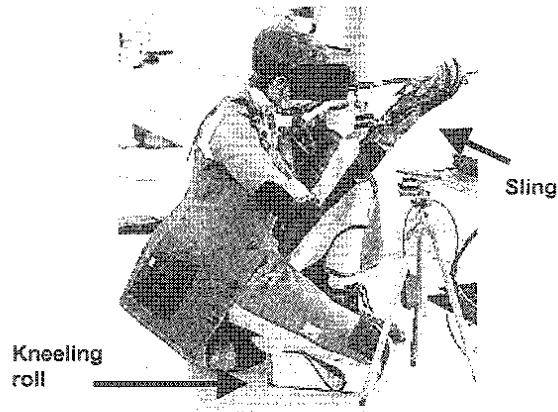

A competitor in the 2000 Olympic Games firing in the kneeling position.

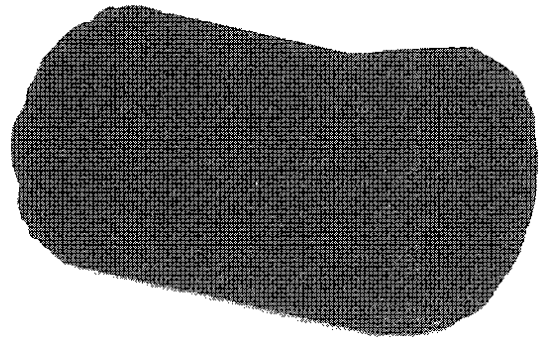

A commercial kneeling roll

Features of Successful Kneeling Positions

Like the standing and prone positions, mastering the kneeling position also must begin by studying the positions of experienced, successful shooters. The first kneeling position photo below, shows Tatiana Goldobina of Russia firing during the 2000 Olympic Games. She won a silver medal

in the women's 50-meter three-position rifle event. The second photo below, shows a school-age shooter with a sporter air rifle. The arrows on both photos point out the key features to study and copy when you begin to shoot in the kneeling position.

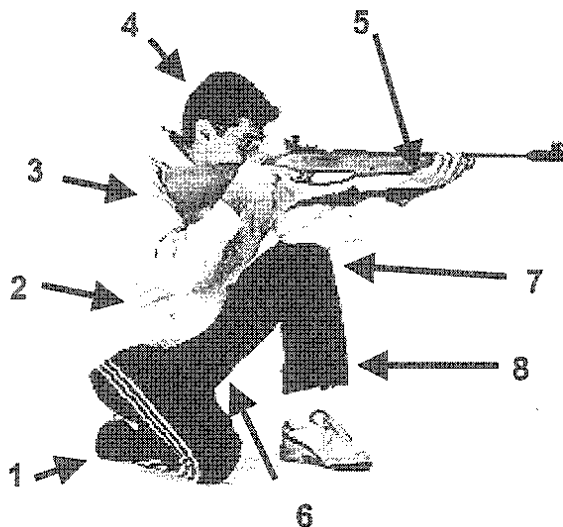
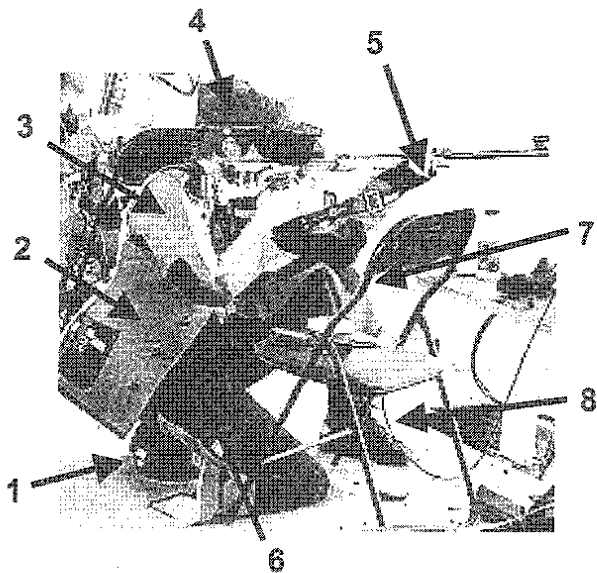

Kneeling position features that are marked with arrows are:

1. Foot is placed on a kneeling roll. The kneeling roll allows the shooter to comfortably sit on the foot for long periods.
2. Almost all of the weight of the shooter's body rests on the heel.
3. The torso is fairly erect, but the shoulders are rolled forward. The shoulders, however, are not erect, but instead are rolled forward or slumped down.
4. The head is fairly erect. It is tipped toward the target, but not to the right.
5. The support hand (left hand) location is far enough back on the fore end to place the rifle fairly high in the shoulder and keep the head erect. The sling supports the weight of the rifle.
6. The body is turned 30-45 degrees away from the target.
7. The elbow of the support (left) arm is located on top of the knee. Other successful shooters place the left elbow just behind the knee. The elbow is normally not placed ahead of the knee.
8. The left lower leg that supports the rifle (left leg) is vertical. Some shooters move the left foot farther forward so that the foot is slightly in front of a point directly below the knee. The foot is never pulled back so that it is behind this point.

Learning the Kneeling Position

The step-by-step process for developing a kneeling position is almost identical with the steps that are followed in learning the prone position. Working out a position first without the rifle and then with the rifle, but without the sling, are

especially important in kneeling. These steps help you establish the correct relationships between the different parts of your body. Do not skip these steps.

- *Study the position.* Take the time to go through each of the eight points identified in the position illustrations. Visualize how you will place your body in a similar position.
- *Kneeling position without rifle.* Begin by placing your kneeling roll on your firing point. Turn it so that it points between 30 and 45 degrees away from the target. After you practice the kneeling position for several days, you can adjust this angle so that it is most comfortable for you.
 - Next, kneel down and place the front part of your ankle over the kneeling roll. Then sit on your right heel.
 - Sit back on your heel so that as much of your body weight as possible rests on the heel.

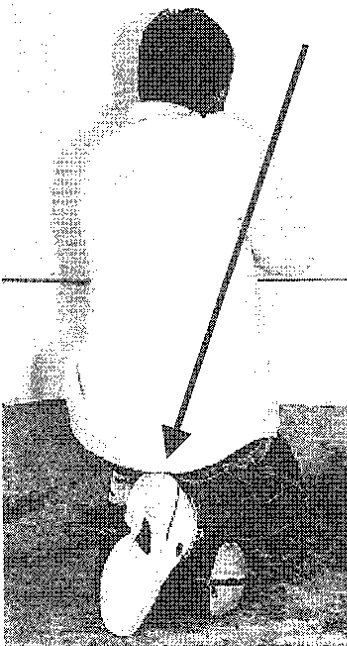

Keep the foot vertical and sit with your weight on the heel

To start building the kneeling position, place the kneeling roll on the floor and turn it 30-45 degrees from the target. Place your ankle on top of the kneeling roll and sit on your heel.

- Do not be discouraged if it is uncomfortable at first to sit on a kneeling roll with all of your body weight resting on your heel. If you have problems with this, try improvising a kneeling roll at home so you can practice sitting in this

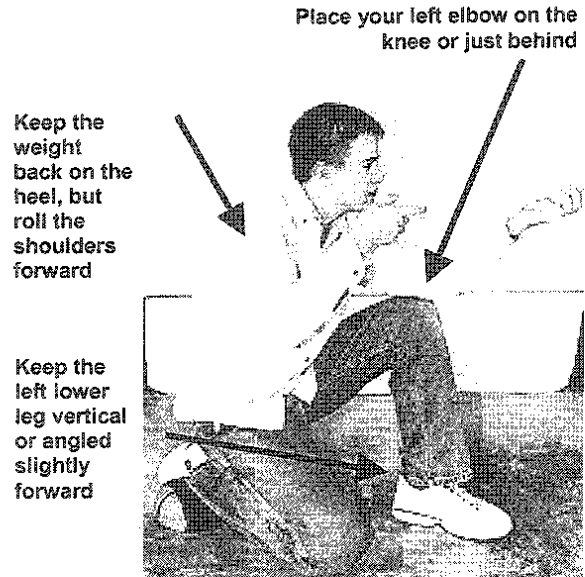

Keep the weight back on the heel, but roll the shoulders forward

Keep the left lower leg vertical or angled slightly forward

Place your left elbow on the knee or just behind

position for periods of ten to 15 minutes while you study or watch TV.

- Next, position the support leg (left leg for right-handed shooter) so that the lower part of the leg is vertical or slightly forward of a point directly below the knee. Do not pull the foot back behind the knee.
- With the body weight on the heel, let the shoulders slump down or roll forward. You should keep your weight back on your heel, but you are not supposed to sit up straight in kneeling.
- Lift the support (left) arm and hold it above the knee. Then simply drop the elbow onto the knee or leg. Depending upon how your body is built, your

support elbow may fall on the knee or it may fall on the upper leg just above the knee.

- Complete the kneeling position without the rifle by lifting the right arm to hold an imaginary rifle. Think about how your body feels in this position. Try to relax your body and balance your body weight over your heel.
- *Kneeling position with rifle, without sling.* The next step is to pick up the rifle and hold it in position. Pay close attention to finding the correct position for the butt plate in the shoulder and for the left hand on the fore end.
 - Position the butt plate in the shoulder, close to the neck, and high enough that your head is fairly erect.
 - Move the support (left) hand forward and rearward on the fore end to find the hand location where the sights are raised to the level of the target. When the correct hand location is identified, mark the point where the V between the thumb and hand lies on the fore end.

Place butt high enough in shoulder to keep head erect.

Shift left hand forward and rearward until sights are at target height. Move sling swivel back to the hand and tighten it.

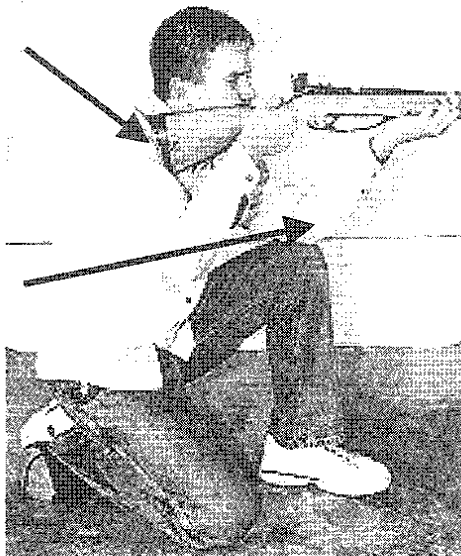

Move the sling swivel back to the left hand. Then tighten the sling until it fully supports the weight of the rifle.

- *Kneeling position with rifle and sling.* All that remains is to complete the position by adjusting the sling swivel and tightening the sling.
 - To start this step, place the sling loop on the arm. Tighten the sling loop so that it does not slip down on your arm. Adjust the sling so that it is much too long and position the sling swivel far out on the fore end.
 - Replace the rifle in position on the shoulder with the sling on. At this point, the sling should still be adjusted so that it is too loose or long.
 - Return the left hand to the location marked on the fore end. Move the sling swivel back to the hand and tighten it.
 - Complete the position by tightening the sling until it fully supports the weight of the rifle.
 - Check the alignment of the position on the target. If your natural point of aim is left or right of the target, align the

position by rotating the entire position (left foot and right knee) on the kneeling roll. If the rifle points above or below the target, it is necessary to move the left hand back to raise the rifle or forward to lower the rifle. The sling and sling swivel will have to be readjusted as part of this change.

Kneeling Position Firing

You will probably begin your firing exercises in kneeling by dry firing. Use your dry fire repetitions to work out the shot technique that you will use in kneeling. Try to follow these steps as you dry fire each shot.

- Close the bolt, place the butt in your shoulder, and align the sights on the target.
- Breathe naturally, exhale, and stop breathing—let the left arm relax so that only the sling holds up the rifle.
- Take up the trigger slack and add some pressure to the trigger.
- Center your hold movement (sight picture) and add more pressure to the trigger until the shot releases

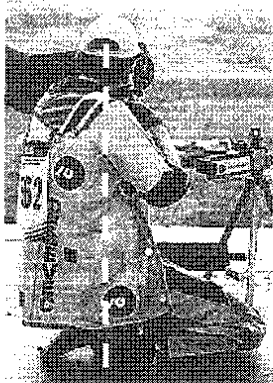

When firing in the kneeling position, keep the weight of the body and rifle balanced over the heel. The balance line on this kneeling illustration shows how the weight of the body and rifle are to be balanced over the right heel. The shooter is Raimond Debevec, Slovenia, 2000 Olympic gold medal winner in men's 50 meter three position rifle.

Conclusion

As you make dry and live fire shots in kneeling, think about your position to be sure 1) your body weight is resting on your heel, 2) your left lower leg is vertical, 3) your left elbow rests on your left knee or upper leg just above the knee, and 4) your sling is tight enough to fully support the weight of the rifle.

If you do a good job of relaxing and balancing your body above the right heel, your kneeling position should produce scores that are almost as good as your prone scores. ❖



To cock and load the M853/753 pneumatic air rifles in kneeling, take the rifle from the shoulder and the hand out of the sling. Work the cocking lever, replace the left hand in the sling, load the pellet and replace the butt in the shoulder.

U.S. MARINE CORPS, JROTC
Category 5 – General Military Subjects
Skill & Marksmanship

Practice and Skill Development

PURPOSE

This lesson will help you understand how marksmanship skill is developed through study, analysis, and practice.

Introduction

In previous lessons you learned the basic elements of target rifle shooting. These basics included safety; equipment; the standing, prone, and kneeling positions; the technique of firing shots; sight adjustment; and scoring. This lesson shows you how to put all those basics together so that you can play a complete game or, as it is called in shooting, fire a complete course of fire.

This lesson also begins to teach you some important ways to become a better shooter. When you reach the point where you can fire a complete course of fire, you are also ready to learn how to improve your shooting. The most effective ways to improve your target rifle scores are covered in this lesson. Those ways are practicing, keeping a shooting diary, using a **shot plan**, and learning to relax and balance your position before each shot.

Target Rifle Rules

The most common three-position air rifle competition event for JROTC and high school rifle teams is the 3x10 event. 3x10 means firing 10 record shots in each of the three positions, prone, standing and kneeling. JROTC rifle team members also sometimes fire 3x20 events (20

shots in each position) in major competitions. The 3x10 and 3x20 events are sometimes also called courses of fire.

The standard instructional technique for teaching every complex sport is to break the game down into different individual **skills** and then to teach those separate skills one at a time. A golfer learns stance, grip, and various stages of the swing before putting it all together. The same approach is used in shooting. Completing a 3x10 shooting event means putting everything you have learned so far together, to play a complete game of target rifle shooting.

When you are ready to play a complete game in any sport, there are special rules for that sport. Sport rules provide order and consistency for competitions and ensure fair play among all participants. The rules that govern three-position air rifle shooting are called the National Standard Three-Position Air Rifle Rules. A National Three-Position Air Rifle Council establishes these rules. The Council includes representatives of almost all major shooting sports organizations and the military cadet commands (Army, Navy, and Marine Corps JROTC).

This rulebook is often called the “Blue Book.” A copy of the National Standard Rules should be available at your JROTC unit. If a copy is not available there or if you want to print out a copy of your own, check the Civilian Marksmanship Program Web site at <http://www.odcmp.com/Forms/3posair2001.pdf>. A complete copy of the National Standard Rules is posted at that Web site.

In competitions, the 3x10 event has a specific order for the positions to be fired as well as time limits for preparation before the event, for

U. S. MARINE CORPS. JROTC
Category 5 – General Military Subjects
Skill 8 – Marksmanship

each of the positions, and for changing from one position to the next. The chart shows how this event is conducted.

Individual 3x10 Event	Time Limit
Preparation period	10 minutes
10 shots prone	15 minutes
Change-over period	5 minutes
10 shots standing	20 minutes
Change-over period	5 minutes
10 shots kneeling	15 minutes

When you fire a shooting event according to competition rules, there are some rules you will especially need to know.

- *Time Limits.* In competitions, there are time limits for each position. In the 3x10 event, competitors have 15 minutes to fire 10 shots prone, 20 minutes for 10 shots standing, and 15 minutes for 10 shots kneeling. The time limit includes the time for practice or sighting shots that must be fired before the 10 record shots for each position. No shots may be fired after a time limit expires.
- *Preparation Period.* Shooters must be given 10 minutes before the start of the first position, prone, to set up their equipment, and prepare to fire. Shooters should get into position during this period and dry fire to prepare for shooting. Dry firing is permitted during preparation periods. However, it is not permitted to charge air rifles with gas, discharge gas or load and fire a shot during preparation periods.
- *Changeover Periods.* Shooters are given five minutes between positions to change their equipment and prepare for the next position.

Shooters may get into the next position and dry fire during the changeover period.

- *Team Events.* Teams normally consist of four shooters. Team members must be named before the competition starts. Team scores are calculated by adding the individual scores of the four team members.
- *Sighters and Record Shots.* The targets that each shooter fires at are designated as either sighter or record targets. Shots fired on sighter targets are for practice. Most shooters fire several sighting shots before they start for record, to determine whether sight adjustments are necessary. Sighting shots also serve as warm-up shots. Every shot fired on a record target counts in the shooter's score. Once a shooter begins to fire record shots it is not permitted to return to the sighter or practice target.

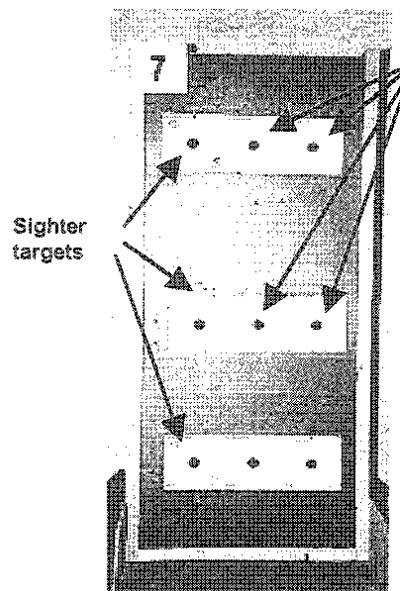

A target stand with BMC targets in place for a 3x10 event. The lowest targets are for prone, the middle targets for kneeling and the highest targets for standing. One target for each position is designated as a sighter target (marked with an "S") and two are designated as record targets. On the BMC target, shooters should fire five shots at each record target.

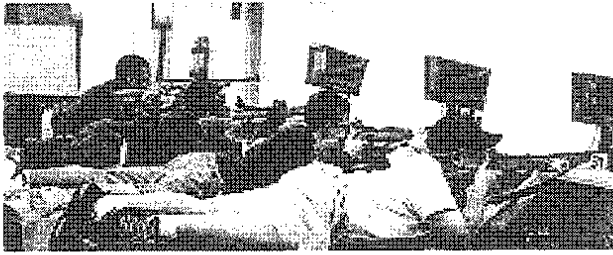

The 3x10 course of fire begins with firing sighters and 10 record shots in the prone position. It continues with firing in the standing and kneeling positions.

The first time you fire a 3x10 course of fire will probably be in a practice setting where the instructor will not enforce time limits. By the end of the marksmanship course, however, you should have an opportunity to fire a 3x10 event where official time limits are enforced. When you do this, the procedure you follow should include these steps.

- After the instructor or range officer calls you to the firing line and starts the preparation period or gives instructions to get ready, lay out your shooting mat and rifle and prepare to fire in the prone position.
- Get into the prone position and align your position on the prone sighter target. Dry fire several times to check your position and prepare to fire. Dry firing is permitted during the preparation period.
- After the commands LOAD, START, are given, fire three or four practice shots on your sighter target. If you have a spotting scope or a pair of binoculars available to see the location of your shots, check to see if your shot group is centered or if sight adjustments are required. If you do not have an individual spotting scope or binoculars, your instructor may have one. Coaching assistance is permitted during sighting shots in most competitions. The instructor or coach can check the sighting targets of the shooters on

the firing line to advise them if sight adjustments are needed.

- After firing few sighting shots to be sure your rifle is zeroed, “go for record” by shifting to your first record target. You may need to move your whole body slightly to be sure your natural point of aim is aligned on the new target. Fire five shots on each record target. Shift your position to the second record target and fire five shots on it.
- When you finish 10 record shots in the prone position, open your rifle action and lay it on the mat. You may get out of position and move to the rear of the firing line after the instructor has inspected your rifle to be sure the action is open.
- When all cadets complete 10 record shots in the prone position, you will be instructed to change targets and prepare for firing in the standing position.
- After the commands LOAD, START, are given, you should again fire a few sighting shots and five record shots in each target from the standing position.
- The process of changing from standing to the kneeling position should be the same as it was from prone to standing. After you are in the kneeling position, the commands LOAD, START, will be given for you to begin firing in this position.
- After all 30 record shots are fired, you will have an opportunity to score your targets and post scores on a chart or score sheet.

Practice -The Key to Improvement

Shooting is a skill sport where natural ability has little to do with ultimate success. Fortunately in shooting, how much a person practices, is the most important determinant in how well that person does. Shooting is also a sport where your first scores on targets are not a good way to predict how well you will ultimately do. The best way to predict how well someone will do in shooting is again, how much he or she are willing to practice. A shooter with the motivation to practice and work hard will almost always do well.

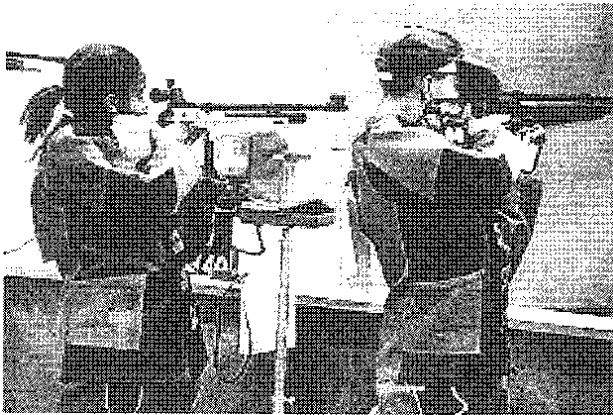

Two JROTC rifle team members in a practice session. They are using precision air rifles and shooting jackets that are permitted in many school competitions. Practices should be as frequent as possible and stress work in the standing and kneeling positions.

If you want to improve in rifle shooting, take advantage of the practice opportunities that your instructor makes available to you. When you have a chance to practice, spend as much time on the firing line actually shooting as you can. There are some important training principles that also will make your practices more productive.

- *Frequency.* The more times each week that you can practice, the better you will become.
- *Difficulty.* Spend more time on the most difficult positions, standing and kneeling.
- *Problem Solving.* When you are having a special problem with some phase of your shooting, spend extra time trying to solve the problem. Ask your instructor to help you find books or other resources that will give you information about how to solve the problem.
- *Goals.* Set short-term goals for your practice. For example, you may set a goal of shooting all of your shots inside the 8 ring on the BMC target or making a smooth trigger release on all your shots in a 3x10 course or having the left arm completely relaxed on every shot. Goals can also be focused on scores or averages if they are realistic and attainable.

Keeping a Shooting Diary

One of the best ways to advance in target shooting is to keep a Shooting Diary. The diary is a written record of all practice and competition firing. Keeping a diary gives you an opportunity to write down things that you learn or to identify problems that you need to solve in future practices. A diary is one of the best ways to analyze your shooting so that you can reinforce what you are doing right and correct what you are doing wrong.

U.S. MARINE CORPS. JROTC
 Category 5 – General Military Subjects
 Skill 8– Marksmanship

<i>This is a Shooting Diary page with one part left blank and one part filled out, to show how information is kept</i>				
<i>Date</i> Shooting Diary.	Location	Rifle/Ammunition:	Training/Competition	
Scores-Prone	Scores-Standing	Scores-Kneeling	Totals	Sight Changes KN to PR +/- _____ L/R _____ PR to ST +/- _____ L/R _____ ST to KN +/- _____ L/R _____
What I Learned				
Problems to Solve				
<i>Date</i> 15 October 01	<i>Location</i> School Range	<i>Rifle/Ammunition:</i> Daisy 853, reg. pellets	<i>Training/Competition</i> Practice	
Scores-Prone 92	Scores-Standing 78, 86, 83	Scores-Kneeling 91,86	Totals Practice	Sight Changes KN to PR +/- <u> +4 </u> L/R <u> L2 </u> PR to ST +/- <u> -2 </u> L/R <u> R3 </u> ST to KN +/- <u> -2 </u> L/R <u> L1 </u>
What I Learned <i>My standing scores got a lot better after my first ten shots when I started checking my balance before each shot.</i> <i>My first kneeling was very good for me—I concentrated on keeping the bull inside the front ring—I stopped paying attention to that on my second 10 and my score went down.</i>				
Problems to Solve <i>In prone, when I get back into position after loading I am not getting my left arm relaxed—I have to learn to do that.</i> <i>In kneeling, I do much better when I really concentrate on my sight picture—I must do that on every kneeling shot.</i> <i>I still have quite a bit of body movement in standing—I think I can stop some of that by checking my balance before every shot.</i>				

This is a Shooting Diary page with one part left blank and one part filled out, to show how information is kept in a Shooting Diary.

Copies of blank Shooting Diary pages will be provided to you during the marksmanship course. Entries in your Shooting Diary should include:

- Data about the firing activity including date, rifle and pellets used, etc.
- Scores you fired in each position.
- Sight changes you make (or should have made) when you fire in each position (+/- means clicks up or down, L/R means clicks left or right).
- Write down at least one thing you learned or did well during your firing exercise.
- Write down at least one problem you encountered that you would like to correct the next time you practice.

Developing a Shot Plan

One of the keys to marksmanship success is consistency. Consistency is doing exactly the same thing at the same time each time you fire a shot. The best way to develop consistency is to have a “shot plan.” The shot plan is simply a step-by-step outline of the different things that you do to fire a shot. Using the same techniques each time you fire a shot is so important in learning target skills, that even beginner shooters should have a shot plan.

It is easy to prepare a plan. Think about each step that you follow when firing a shot, from loading the rifle, to placing it in position, to the details of your shot technique. Decide how you do each of those steps. Write that action down in your plan.

Once you have a shot plan, it is important to follow your plan on every shot you fire. The more closely you follow your plan, the more

effective the plan will be in helping you develop consistency that leads to improved scores.



Developing a personal shot plan means starting with how you load the rifle and then determining exactly how you perform each step in sequence in firing a shot. Shot plans work wonders when they are followed for each shot fired.

PERSONAL SHOT PLAN	
SHOT PLAN STEP	DESCRIPTION OF HOW THIS STEP IS DONE
Loading	<i>Use left hand to open and close cocking lever. Use right hand to take pellet from pocket, load and close bolt.</i>
Placing rifle in position	<i>Lift rifle to shoulder, but butt plate on arm-shoulder joint. Hold rifle with right hand, form fist with left hand, put fist under cocking handle, get left elbow under rifle and drop arm and rifle onto side.</i>
Align rifle with target	<i>Start with front sight above target and lower rifle down to bull's-eye.</i>
Pre-shot checks	<i>Check to be sure left arm relaxes and is directly under rifle. Check balance—weight should be evenly spread on both feet.</i>
Breathing	<i>After checks, take two more breaths, let it out and hold.</i>
Aiming	<i>As soon as I start to hold my breath, try to center the bull's-eye in the front ring.</i>
Starting to squeeze trigger	<i>Take up the trigger slack when I start to aim. Put about half of the pressure on the trigger immediately.</i>
Hold control	<i>Concentrate on the sight picture, try to hold the bull inside the front sight ring as much as possible.</i>
Completing trigger squeeze	<i>When the sight picture is centered, add another step of pressure to the trigger. When it is centered again, add another step. The shot should go after two or three steps.</i>

*The "Personal Shot Plan", illustrated here, demonstrates a shot plan for a beginner shooter who uses a pneumatic air rifle and sporter class equipment. Normally a separate plan is prepared for each shooting position.
 (This plan is for the standing position.)*

The key to having an effective shot plan is identifying how you complete each of the steps listed. By writing them down you have a plan that you can now follow for each shot that you fire. There is no perfect shot plan for every shooter. Each shooter will have different ways of doing each of these steps. It is not as important that you do something a certain way as it is to have a plan that assures that you do it your way every time you fire a shot.

Pre-Shot Routine

To consistently fire accurate shots, one additional action is necessary. To do your best on every shot, you also must learn to properly prepare for each shot so that your body performs its very best in holding the rifle steady. For your body to hold the rifle as steady and well controlled as possible, it must be:

- Balanced, with the body-rifle system centered as perfectly as possible over the support points for the position.
- Relaxed, with only the minimum muscle tension necessary to hold the rifle being used.

The best way to assure that your body is relaxed and balanced when you fire each shot, is to perform a simple pre-shot check before each shot. This should be done after the rifle is placed in position and before you start to aim at the target.

You may have noticed that in the Personal Shot Plan chart you just looked at, that there was a blank for “pre-shot checks.” To make a pre-shot check, just take a few extra seconds after aligning the rifle with the target to complete these steps.

1. As you bring the rifle down to the target, pause BEFORE beginning to aim. The illustrations at the end of this lesson show how two champion shooters who competed in the 2000 Olympic Games, pause to make pre-shot checks before they start to aim.
2. The first check should be for balance. In the standing position, take a few seconds to think about how the weight of the body and rifle is distributed on the feet. The weight should be balanced equally between the feet (left-right balance) and between the balls and heels of the feet (forward-rearward balance). In the kneeling position, the weight of the body and rifle should be balanced above the right heel on the kneeling roll and the left heel that supports the weight of the arm and rifle.
3. The second check is to make sure the body is relaxed. Do this by taking two or three breaths. Each time you exhale, let the muscles in your body relax or let go, especially the muscles in your support (left) arm. Do not start to aim and fire the shot until you feel calm and relaxed.
4. When your shot plan is written out, it should identify how you check your balance and relaxation before you start to aim and fire.

Conclusion

This lesson has prepared you to fire a 3x10 event. Now you know how to play a complete game of three-position air rifle target shooting. This lesson also provided your first insights into how to improve your skills and scores as a target shooter. If you remain active in target shooting, you will discover that the challenge of becoming a better target shooter is a quest that takes many years of training, where you continually discover new ways to improve.

Achieving excellence in all sports requires that kind of effort, but it is especially important in shooting. ♦

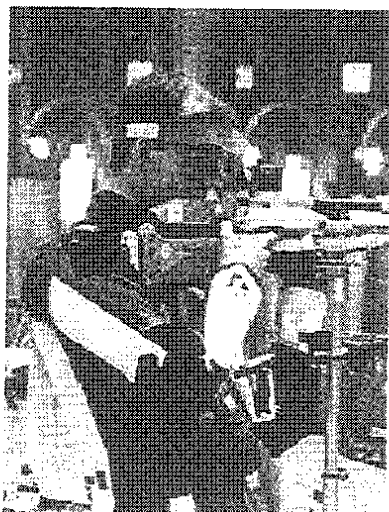

U.S. MARINE CORPS. JROTC
Category 5 – General Military Subjects
Skill 8 – Marksmanship

Competition Opportunities

PURPOSE

This lesson will teach you how to complete a competition course of fire.

Introduction

Many cadets take rifle marksmanship instruction to learn a new sport and how to practice it. Many others take rifle marksmanship because they are interested in **competition** target shooting. Trying to become a member of the school rifle team is challenging and exciting to many cadets. This **final** lesson in the *JROTC Rifle Marksmanship Student Text* is for those who want to “go for it” and try competition shooting. It informs you about opportunities that are available to you in the sport of target rifle shooting.

This chapter first introduces the official competition target that is used in JROTC, school and other three-position air rifle competitions, as well as in all major air rifle competitions around the world. You will learn about finals that now conclude most major target competitions, from important junior competitions to the Olympic games. The lesson ends with a review of the different competition activities that you can participate in, as a member of a JROTC rifle team.

The Competition Event

One big change between the 3x10 practice events that you have fired on the BMC target and regular 3x10 competition events, is the target. The official competition target has a tiny dot for a ten ring and all of its scoring rings from the 1-ring to the 10-ring are slightly smaller than the eight ring on the BMC target.

If you learned and practiced the basics of rifle marksmanship taught in the JROTC rifle marksmanship course, you are probably ready, or with a little more practice soon will be ready, to graduate from the BMC target to the official competition target. If you are able to keep your shots inside the 8-ring on the BMC target, you will now be able to keep your shots inside the scoring rings on the more difficult official target.

When firing a 3x10 or 3x20 competition event on the new target, there also is a difference in how the targets are configured. The competition targets are printed so that there are two sighting targets and ten record targets on one target card. Even after a few months of practice, shooters’ skills become good enough that when five shots are fired on one target, the shots often are so close together, it is not possible to score them accurately. For this reason, competition shooters fire only one record shot on each competition target.

Many basic marksmanship courses end with everyone shooting a 3x10 course of fire on these competition targets. Cadets who join the rifle team will do all of their practice and competition on this target.

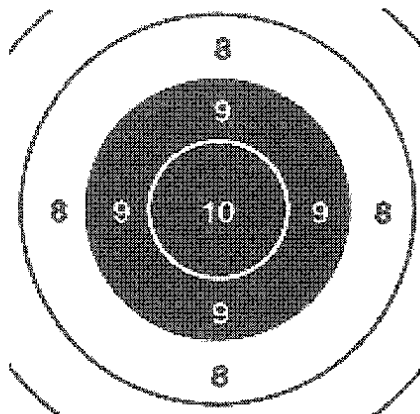

The 8-9-10 rings of the BMC target.

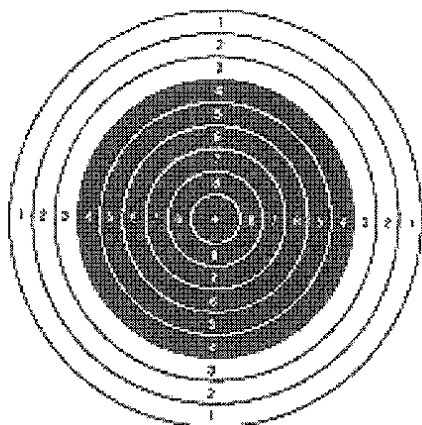

The official 10 m air rifle competition target. The 10-ring is a 0.5 mm dot and the one ring is 45.0 mm in diameter.



Sporter air rifle finalists in the 2000 Junior Olympic National Championship prepare to fire one of their final round shots. The top eight shooters advance to the final. Finalists fire ten additional shots together, one-shot-at-a-time. Final round scores are added to the shooters' scores in the regular competition.

Finals

If you become a rifle team member and your team attends major three-position competitions, you will probably go to an event where a final is fired. Even if you do not go to a competition with a final, the final system can be used for shooting games on your home range that are really fun. Finals are a relatively new and very exciting way to conclude target shooting competitions. Here are some important facts about finals.

- Shooting finals were first used in the 1988 Olympic Games. Finals are now used in almost all important target shooting competitions, including many competitions for high school teams.
- To advance to a final, a competitor must complete the first round of a competition and finish in the top eight. The eight shooters with the highest 3x20 scores qualify for the final. In some competitions, all shooters may be invited to shoot the final.
- In three-position events, the final is always fired in the standing position. All eight shooters in a final, shoot together on adjacent firing points. The shooter who finishes the first round in first place takes the number one position on the left. The shooter in eighth place takes the number eight position on the right.
- Finals start with a three-minute preparation period. A seven-minute sighting (practice and warm-up) period follows. Then finalists fire 10 shots for record, one-shot-at-a-time.
- To start each final round shot, the range officer uses the commands: FOR YOUR NEXT SHOT, LOAD, (pause), ATTENTION—3-2-1-START. Finalists have 75 seconds to fire one shot.

- After all eight finalists fire one shot, scores for that shot are announced. When electronic targets or special scoring equipment is available, final round shots are scored in tenth-ring values. A perfect center ten counts 10.9 points, while a ten that just touches the 10 dot scores 10.0 points. The range officer announces the eight shooters' scores after each shot ("Shooter one, 10.2; Shooter two, 8.7; Shooter three, 9.9; etc.").
- In many smaller competitions where special scoring equipment is not available, finals are still held, but scoring is done in whole numbers. When paper targets are used, the range officer can use a telescope to estimate and announce the shot values ("Shooter one, 9; Shooter two, 7, Shooter three, 10, etc."). The targets can then be "officially" scored immediately after the ten shots are completed so that final results can be announced.
- Spectators are encouraged to watch finals. Cheering before and after each shot is common and encouraged. At the 2000 Olympic games in Sydney, there were 2,500 spectators in a grandstand behind the finalists. In addition, a live television signal of the shooting finals was broadcast to as many as two billion people around the world.
- Each finalist's final score is the total of the first round (3x10 or 3x20 shots) plus the final round score.
- Final scores are counted in individual rankings. Final scores are not counted in team scores or rankings.



Men's air rifle finalists at the 2000 Pre-Olympic test competition in Sydney. The targets on this range are electronic. Note the scoreboards and monitors above each shooter and the electronic scoreboard on the left.

Competition Opportunities for JROTC Rifle Teams

Cadets who are interested in target rifle shooting as a sport and who become members of their JROTC or school rifle team have many special competition opportunities. Competitions are a great way to measure your skills and progress as a shooter. They are always exciting, challenging experiences where you learn to control yourself and do your very best under pressure. They also offer opportunities to travel and meet new friends. Competition opportunities available to you include:

- *JROTC or School Rifle Team.* If your school has a JROTC rifle team or the school rifle team, your instructor will provide information about that program. Team members have a chance to practice regularly during the rifle season and to participate in competitions scheduled for the team.
- *Postal Competitions.* In postal competitions, participating teams schedule matches where each team fires their score at their home

range. Competing teams exchange scores by email, fax, or phone to determine who won. There are also national postal competitions that are popular with many JROTC rifle teams. The National Guard Bureau and American Legion sponsor the two most popular national postals. To learn more about a competition of this type, check the American Legion Web site at: <http://www.legion.org/americanism/jrshoot.htm>



The instructor (front center) and members of a high school JROTC rifle team pose with a trophy they won in a major high school air rifle invitational competition.

- *League Competition.* In many areas of the country, school or JROTC teams in a particular area organize leagues where they compete against each other in shoulder-to-shoulder competitions. Won-lost records usually determine league standings. There are many JROTC or high school leagues in the United States. The largest and most active high school league is in Georgia where the Georgia High School Association recognizes rifle as a varsity sport. To learn more about

this rifle program where participating schools compete in regional leagues, check this Web site: <http://www.ghsa.net/riflery-assn.htm>

- *Major School-Age Competitions.* There are a growing number of major competitions for school and JROTC rifle teams. A program goal of many JROTC or school teams is to do well in one or of these major tournaments. They include:
 - *State high school championships.* In addition to the Georgia program, there are now several other states that have state high school or JROTC rifle championships.
 - *State Junior Olympic Championships.* Almost every state now has a state qualifying competition for the National Junior Olympic Championship in the winter or early spring. Many states organize their qualifiers in three or four different sections so that travel distances are not great and as many teams as possible can participate. Check the USA Shooting Web site for a listing of state qualifying competitions:
www.usashooting.com/Youth/threepair.cfm
 - *CMP Cup Matches.* These are large regional high school competitions where participants come from several states. CMP Cup Matches have sporter and precision class individual and team events and offer an opportunity to earn credit points for Junior Distinguished Badge awards. For a list of these matches, check the CMP Web site:
www.odemp.com/Services/Programs/3P.htm

U.S. MARINE CORPS. JROTC
Category 5 – General Military Subjects
Skill 8 – Marksmanship

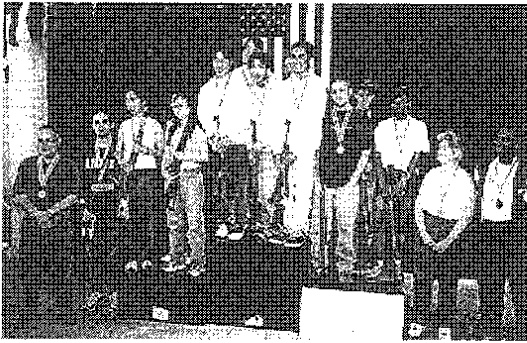

The winning teams in the 2000 National Junior Olympic Three-Position Air Rifle Championship. The top three teams were all high school JROTC teams from Hawaii, California and Georgia.

- *National Recognition Opportunities.* When school age rifle teams participate in major competitions, they become eligible to earn many special awards. Some of the most important awards are the Junior EIC badges and Distinguished Badges that are offered by the National Three-Position Air Rifle Council. Individual shooters who participate in Junior Olympic State and National Three-Position Air Rifle Championships can earn credit points for EIC badges and the prestigious Junior Distinguished Badge that are shown here. Distinguished Badges usually are awarded in special ceremonies.
- There also are National Records for three-position air rifle shooting, including separate record categories for Army, Navy, and Marine Corps JROTC competitors. Check this Web site for information about the EIC and Junior Distinguished Badge program or to see the list of current national records:

www.odcmp.com/Services/Programs/3P.htm

- The most comprehensive summary of all of the competition opportunities available in target shooting appears in the *Youth Shooting Opportunities Guide* that is published by the CMP. If your unit does not have a copy, the guide may be downloaded and printed from the CMP Website: <http://www.odcmp.com/Forms>

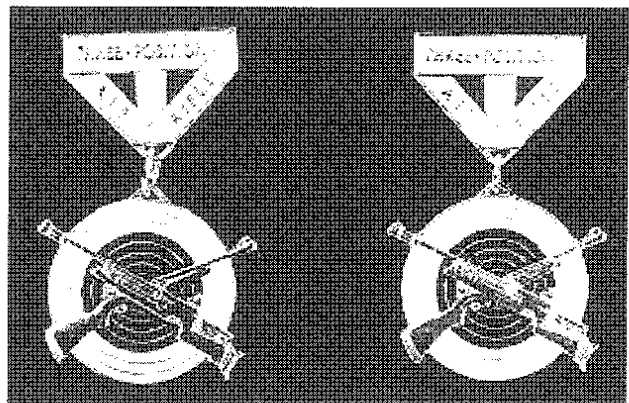

Junior bronze and silver EIC badges

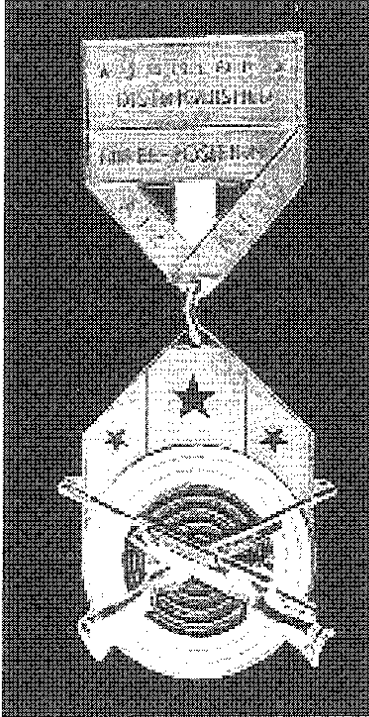

The prestigious Junior Distinguished Badge. The badge is awarded when a school age competitor earns 30 points in designated competitions.

Tips for Successful Competition Opportunities

Most basic marksmanship instruction concludes with class participants firing a 3x10 event on the official air rifle targets under competition conditions (time limits, etc.). If you have a chance to fire a practice competition like that or if you go on to compete as a member of your rifle team, here are a few tips to remember that will help you do your best in the competition.

- *Firing point assignments.* In formal competitions, you will normally be assigned to a specific relay and firing point. Find out when and where you are scheduled to fire and arrive there well in advance so you can be prepared.
- *Be ready!* When the instructor or range officer calls you to the firing line for each position, set up your equipment and get into that position. Be sure to align the position on your sighter target and dry fire a few shots to warm up.
- *Keep your rifle zeroed.* After the commands LOAD, START are given, fire a few sighting shots and check to be sure your shot group is centered. Make sight adjustments if necessary. At any time during a competition that your shot group is not centered, adjust your sights to keep your rifle zeroed.
- *Remember your shot plan.* Consciously follow your shot plan for each sighting and record shots that you fire. If you are doing well, do not count up your possible score—just keep following the shot plan for each succeeding shot. If you have a poor shot, forget about it and remind yourself to just follow your shot plan to try to fire a good shot on the next shot.
- *Excitement is normal.* Everyone, including the greatest champions, become excited and nervous during competitions. Enjoy the feelings of heightened awareness that comes from competition. Keep your mind focused on following your shot plan for each shot. Being excited can actually help you do even better if you learn to control it.
- *Use your time wisely.* It is a good idea to keep a watch or timer in view, so you can pace yourself and make sure you do not run out of time. One of the most common mistakes of beginner shooters, is shooting too fast. Take advantage of the time available to you. Take a little extra time to do your pre-shot checks before each shot.

- *Take the rifle down if something is not right.* If you are not holding steady or are likely to fire a poor shot, stop trying to fire that shot, take the rifle down, rest briefly, and try again. There is plenty of time available to make sure you fire the best shots you can.

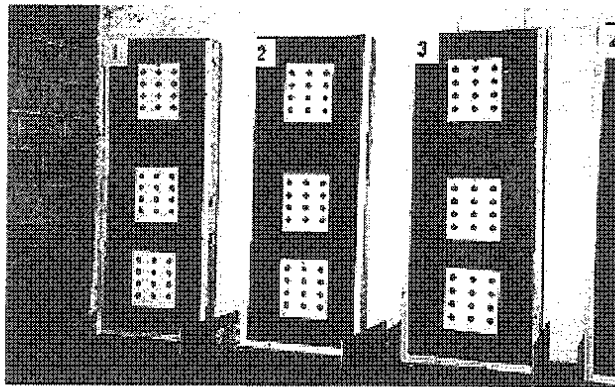

Ten-bull targets in place for firing a 3×10 competition event.

- *Keep yourself under control.* One of the most important lessons to learn in target shooting is the importance of **self-control**. It is natural and good to want to do well when you are in a competition. It is also tempting to become upset when there are distractions or when you fire bad shots or disappointing scores. This happens to all shooters at some point. If something goes wrong for you, take control of yourself, be determined not to let anything bother you and remind yourself that the best thing you can do is use your shot plan to focus on firing your next shot correctly.
- *Enjoy the competition experience.* Competitions are *fun*. Enjoy the experience of trying to do your best while dealing with the challenges of competition. You should always know that when you finish a competition and can say you worked hard to follow your plan and tried to do your best on each shot, that the competition was a success for you. The score

you fired or where you finished in the competition is not important then. What is important, is trying hard to do your best. If you can say you did that, the competition was a success for you.

Conclusion

This student text has introduced you to the sport of target rifle shooting. The safety skills you learned will be invaluable to you, regardless of whether you continue to participate in the sport. If learning about rifle marksmanship sparked a new interest for you in the sport of target shooting, it can open the doors for you to the excitement and special experiences of high school and collegiate rifle shooting. ❖

U.S. MARINE CORPS. JROTC
Category 5 – General Military Subjects
Skill 8 – Marksmanship
